



Made in Finland



WOODI

WOODI 01-2018





Functional learning environments can be accomplished with Woodi furniture

Woodi furniture makes diverse and adaptable learning environments possible, where children can develop and learn to interact with other people. With the right furniture, daily learning situations can expand into all nearby spaces, such as communal rooms, classrooms, corridors and halls. A range of tables equipped with wheels, adjustable chairs and transportable storage and play furniture can be used to achieve a flexible and varied space, which can be used by groups of different sizes, using a variety of teaching approaches.

Woodi furniture is safe and ergonomic, and it can be used to create an environment, that inspires and encourages learning. Solid birch is an ecological material for furniture, and it creates a comfortable and warm atmosphere.

Acoustics have been taken into consideration in the development of Woodi furniture in many ways. Tabletops, back panels of storage units, room dividers and cushion walls are available in Acoustic materials. With these elements, learning environments can be quickly and easily adapted to support work done independently and in teams.

Furniture that directs and encourages play can be placed around the kindergarten. Even corridors can be transformed into active learning environments. Versatile play furniture encourages children to take part in both spontaneous and supervised play. Because the play furniture is equipped with wheels, it can easily be moved to different spaces.



Kindergarten and school

A kindergarten case study	4
Kindergartens and school dining rooms	8
Common rooms	10
Offices and break rooms	11
Open learning environments	12
Classrooms	14

Furniture for communal rooms

Chairs	
High chairs and chairs for children	16
Chairs for adults	19
Stackable stools	21
Tables	
Tables for children	23
Tables for adults	25
Student desks	28
Fold-out table, Heksa table	30
Desks	31
Saddle chairs, office furniture	33
Storage furniture	
Drawers, shelves, cupboards	34
Room dividers	39
Wall shelves	43
Trolleys	44
Benches and toy boxes	46
Activity tables	47
Drawing	48
Music	50
Roleplay	52
Playing house	53



Furniture for lobbies

Sofas	54
Soft furnishings	56

Motor skills and exercise furniture

Motor and sensory skills	60
Climbing and motor skills walls	62
Gymnastic walls	63
Gymnastic wall and stage	65

Furniture for entrance areas

Dressing benches, benches	66
Shoe racks	67
Cloakroom furniture	
Cloakroom furniture for children	68
Special cloakroom furniture	72
Wardrobe accessories	73
Lockers	74
Wardrobes	75
Coat stands, wall racks	76
Cloakroom trolleys	77



Furniture for sleeping areas

Fold-out beds	78
Cabinets	82
Bed linen, sofa- beds	83
Bunk beds, beds, cots	84
Changing tables	85

Product information

Help with planning	87
Laminate colours, Acoustic colours	88
Maintenance	89
References	90





The early childhood education manager for the City of Alajärvi talks about working with Woodi on a kindergarten project

on page 88

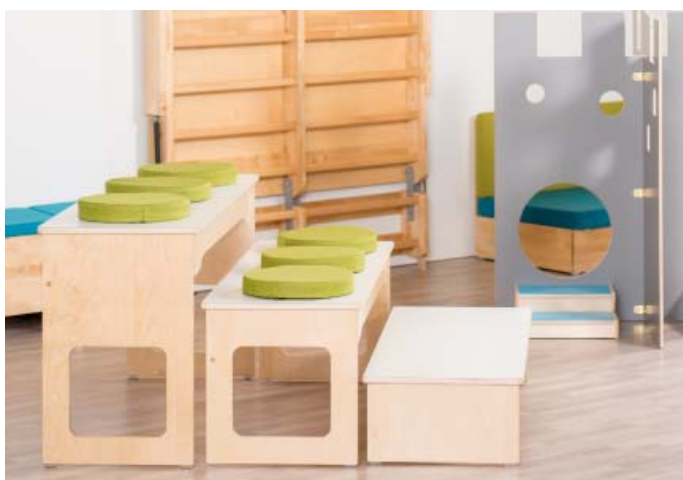

Lobbies and hallways

Furniture that directs and encourages play can be placed around the kindergarten. Even corridors and halls can be transformed into active learning environments.

Small groups and sleeping areas

Children can be motivated to take part in exercise and to experience the joy of movement by adding different types of activating furniture around the kindergarten. This way, they can be encouraged to engage in active games indoors as well as out.



Toys and other equipment are within easy reach in child-sized storage and play furniture. Children also learn about hygiene and enjoying a clean environment, when it is easy to put equipment away.



Small groups

Versatile play furniture encourages children to get involved in spontaneous and supervised play. As children, we learn about the world around us through daily activities and play.



The furnishings of a functional kindergarten are designed to offer opportunities to for pleasant activities, versatile and energetic sports, games and peaceful rest.



Communal room for 12-15 children

Woodi furniture can be used to create versatile and adaptable learning environments for both early years education and schools. Children will develop and learn through interacting in modern learning environments.

Communal room for 21-24 children

A range of tables equipped with wheels, adjustable chairs, and mobile storage and play furniture can be used to achieve a flexible and varied space, which can be used by groups of different sizes, using a variety of teaching approaches.





An example of a layout for a kindergarten

The groups of tables can easily be changed when the tables are equipped with wheels.

Page 28



Five seats can be added to the communal room with a handy fold-out table.

Page 30



Toys and other equipment are within easy reach in child-sized storage and play furniture. Children also learn about hygiene and enjoying a clean environment when it is easy to put equipment away.

Page 34



Every child can be a gardener with growing trolleys. For example, children can grow herbs and use them to spice up their lunches. Growing trolleys work as a beautiful interior element as well.

Page 45



There is a great variety of Woodi furniture, that creates suitable platforms for play. For example, there is a lot of space for toys in the toy boxes that are situated beneath the Woodi bench. The bench can be used as a platform for play.

Page 46





This activity table can also be used as a handy research table. Rocks, pinecones and moss can be collected from outside in the boxes, and research can continue with a magnifying glass on the table.

Page 47



Through play, children learn skills that they will need as adults, and they are empowered through role play. Thanks to the wheels in the trolley, role play can be easily moved to the hallway, and the handy mirror travels along with it.

Page 52



Today, children start to learn about IT at kindergarten. It's easy and safe to recharge tablets and other devices in the charging station. A box full of tablets can be easily removed from the furniture and taken wherever they are needed.

Page 49



Children can train their visual perception with sensory walls by moving their finger along the lines as part of different exercises. Solid birch is a warm and natural material to touch.

Page 60



Ball games, hide and seek, even an energetic game of tag is possible with the exercise castle and anti-slip stands. Moreover, the best thing is that play can be easily transported to another space.

Page 61



Exercise furniture is flexibly placed around the kindergarten so that the corridors can also be used throughout the day. The furniture encourages children to move spontaneously in transitional situations and during playtime. It has been established that climbing and balancing improves memory and other cognitive functions, because exercises that use proprioception also use memory actively.

Page 62





Furniture for dining rooms

Our dining room tables are normally 730 mm high. The chairs for children are equipped with an elevated seat; hence the seat height is 500 mm. Some of the children's chairs are equipped with armrests and safety rails so that the dining room can be used by children of different ages. The chairs do not have dirt-accumulating gaps and they can be hung underneath tables to make cleaning easier. The tabletops are coated with high-pressure laminate or Acoustic-coating.



Acoustics

The acoustics of the space can be improved with room dividers equipped with wheels. The acoustic panels can also be used as a bulletin board, on which drawings and information can be attached with pins. Acoustic dividers make the space more multifunctional because they can be used to divide the room into smaller spaces. An Acoustic high room divider can be attached to a storage unit. With these great acoustic elements, a dining room can be transformed into an active space for the whole day.



It is easy to enjoy a dining space that is functional. When a kindergarten has its own dining room, communal rooms can be burdened with fewer tables, releasing more floor space for group activities, play furniture and play.

Transformability

The multi-functionality of the space can be enhanced with different pieces of small group furniture. The stand bench set can be adapted to create a stand for presentations or a relaxed place for reading in a flash. Other handy furniture includes activity tables and benches with toy boxes, so that the materials and toys used in play are always close to hand. A charging station for tablets can be a staple in a dining room, so that the room works as the technology hub for the kindergarten.



Furniture for dining rooms

The dining room tables are of different heights, which brings variability to the space. Chairs and stools can be hung underneath the tabletops, which are coated with high-pressure laminate or acoustic and hygienic Acoustic coating. A leaf of the tables can be folded against the wall to free up floor space for other activities. The tables in the middle of the room can be easily moved to the edges, as they are equipped with lockable wheels.

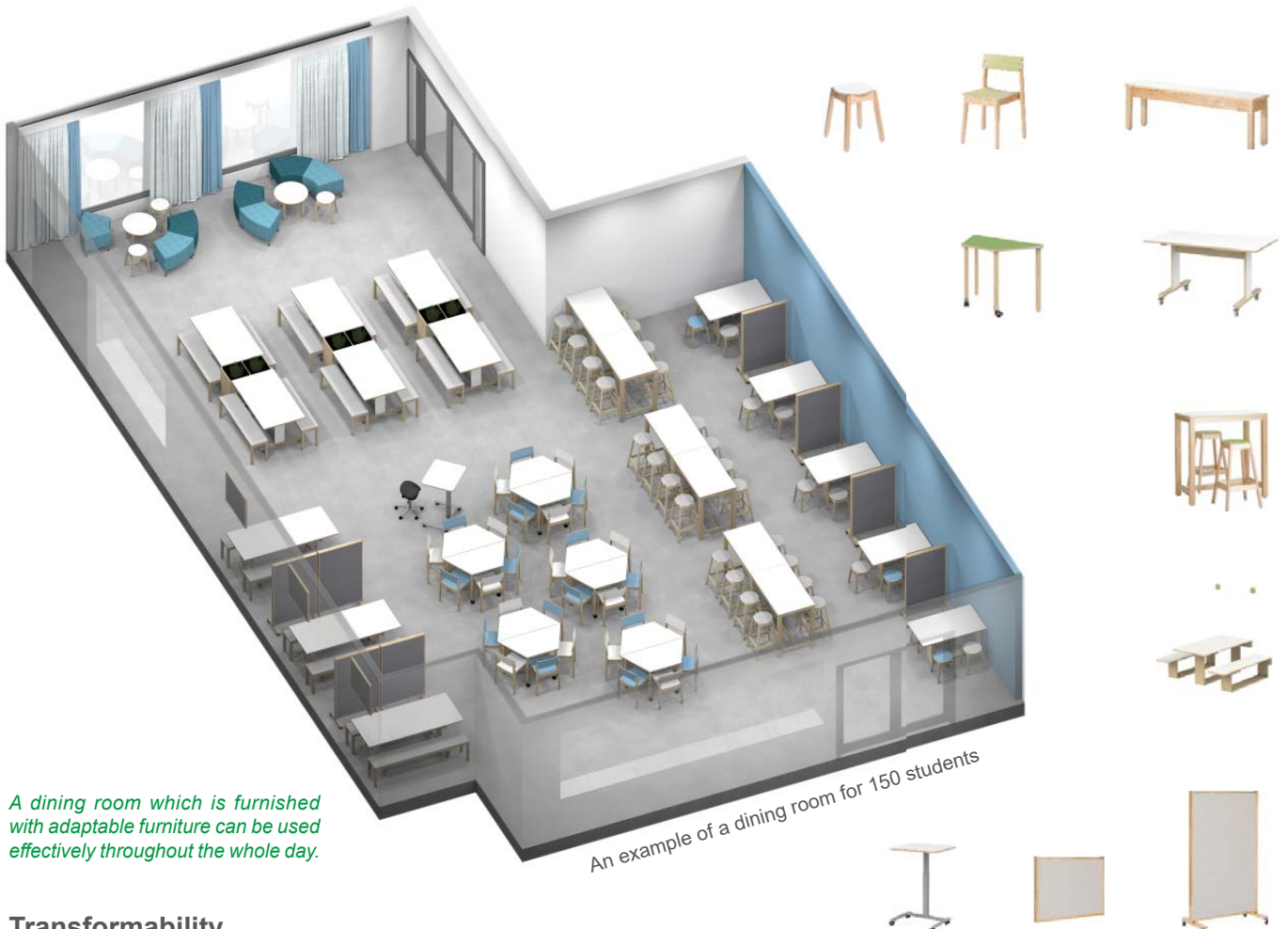

A dining room which is furnished with adaptable furniture can be used effectively throughout the whole day.

An example of a dining room for 150 students

Transformability

In a transformable dining room, the space has been separated with room dividers, equipped with wheels. The room dividers can be used to divide the space to smaller and more peaceful spaces. This way, the room dividers can be used to take into account the individual needs of the students. Acoustic boards on the walls and room dividers improve the acoustics of the space efficiently. A higher seat height (500 mm) should be taken into consideration in community centres, which have a kindergarten. This way, the space can be made ergonomic to everyone who uses the space.



A sporty school day is not just about physical education.

Furniture solutions can be used to increase children's daily movement. Furniture that encourages exercise can be placed in halls, corridors and classrooms. Different kinds of furniture that encourage to movement, such as sensory learning walls, rope climbing and climbing walls, gymnastic walls, slides and pull-up poles can be used by children to develop their sporty skills in a fun way.

For children, walking, running, jumping and climbing are natural ways to move. Furniture that guides children to climb and encourages them to move spontaneously will help them to develop. Sports mats placed beneath the climbing areas make the activity safe. The sensory learning walls have different kinds of climbing elements: a net, climbing boulders and a climbing pole. A climbing net is a challenging platform for children because it bends under the child's weight while they are climbing. This way, the child's balancing skills and proprioception develop while climbing. In the same way, the child's body control and strength increases while climbing on boulders and the pole.

Climbing develops children's problem solving skills and concentration because when climbing, the child has to focus on the task at hand, such as how you get down from the net. While climbing, children also learn to handle disappointment and to develop courage. Good body control is a requirement for reading, writing and mathematical thinking, so climbing will help to develop a good basis for learning. Movement will encourage cell production in the brain, which is necessary for learning.

Different working methods and learning environments are utilised in development and teaching work, and teachers are encouraged to take their work outside the classroom on a regular basis. Syllabus basics 2016





Staff break rooms are places where teachers can relax and exchange thoughts with their colleagues

In the new learning environment, adults are also being freed from having to sit all day. Break rooms are equipped with height-adjustable workstations, and the furnishings are designed to create a cosy and harmonious space. There are sofa and table groups in different sizes instead of one long meeting table. High tables with high stools bring variation and if the space allows it, a few graceful rocking chairs can be added. Workstations are height-adjustable electrically or with gas-assisted springs, and are equipped with saddle chairs.



It is important to take into consideration the acoustics of the space in open learning environments, because there can be different kinds of activities going on at the same time with different groups.

Acoustics have been taken into consideration in many ways with Woodi furniture. Tabletops, back panels of storage units, different acoustic screens and boards can be used to reduce noise. This way, the open learning environment can be transformed into different spaces for individual and group activities, in which everyone has a possibility to take part in the interaction.

Pedagogically flexible space is easy to divide into groups of different sizes and learning can happen individually, in pairs or in bigger groups. By moving a couple of pieces of furniture, the space can be transformed into one large communal room. Tables and storage units, that are equipped with wheels, enable easy convertibility. In addition, the height-adjustable workstations for teachers are also equipped with wheels. The furniture in the space enables people to work standing up, sitting down or even relaxing on the soft furnishings alone or with others.

The space can be used to execute different kinds of activities, and the furniture supports modern learning and teaching methods that encourage both individuality and communality. The open learning space is cosy, ergonomic, unobstructed and aesthetically pleasing, where students and staff can enjoy themselves.

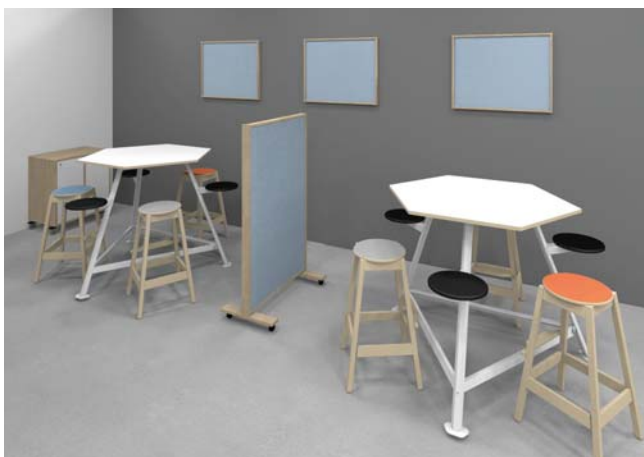

There is a great variety of seats: soft and hard, high and low, adjustable and active.



The student desks are specially designed for learning environments. The tables can be used individually or they can be combined to create groups of different sizes. Due to the wheels, the tables are easy to move from one place to another.

A basic learning concept according to the 2016 syllabus: Learning happens in interaction between other students, teachers, other adults, different communities and learning environments.

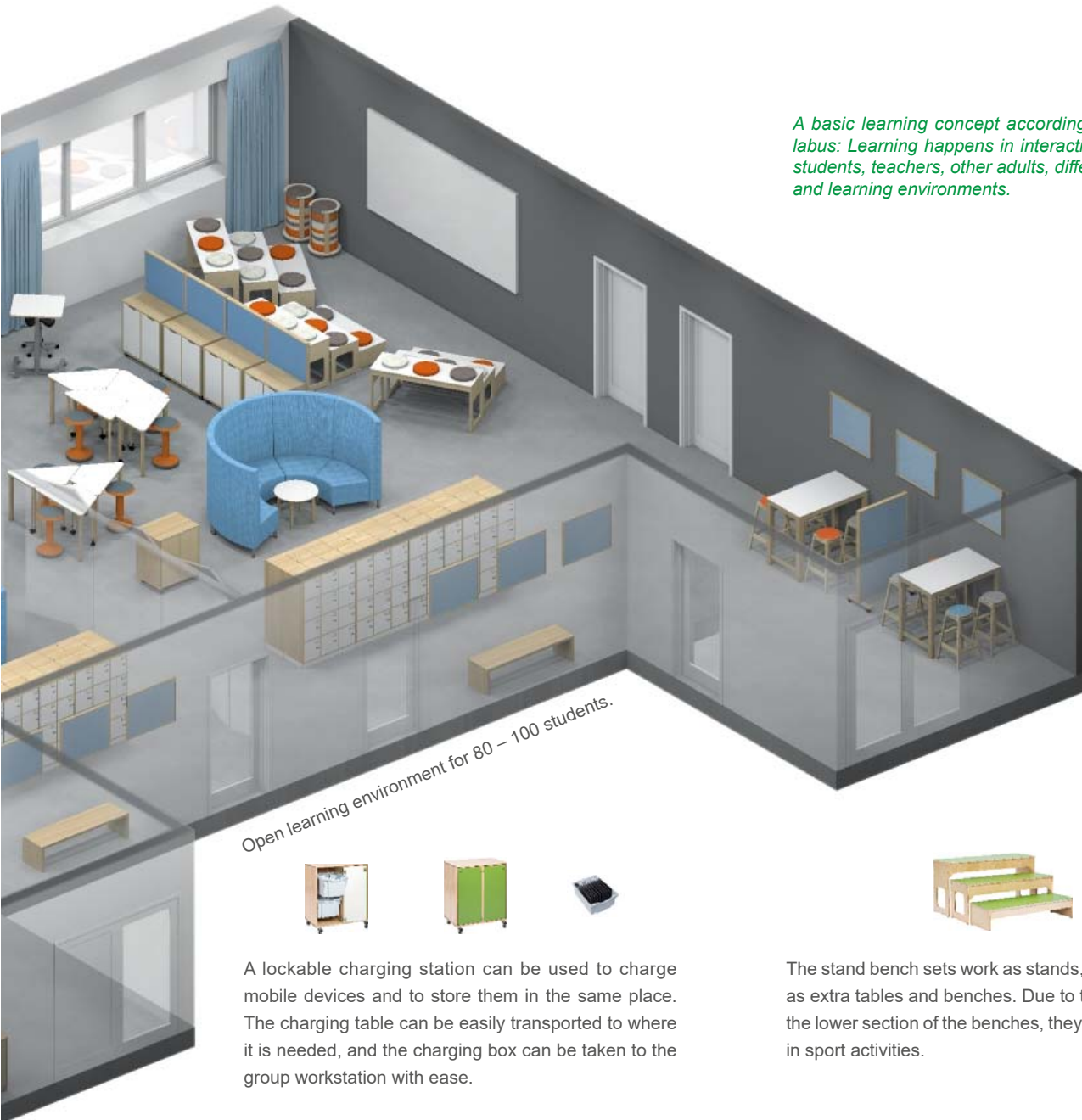

Open learning environment for 80 – 100 students.



A lockable charging station can be used to charge mobile devices and to store them in the same place. The charging table can be easily transported to where it is needed, and the charging box can be taken to the group workstation with ease.

The stand bench sets work as stands, stages and even as extra tables and benches. Due to the crawl holes in the lower section of the benches, they can also be used in sport activities.



The Heksa table has three sitting and three standing spots around it. The tabletop is coated with white board, so it can be used to jot down the results of group work.



It is easy to take a floor cushion from the cushion cart and sit wherever you want.



Storage units are equipped with high acoustic backboards and they can be used to confine the space. The units are equipped with wheels so they are easy to move around, and at the same time the necessary equipment can be moved on board.



Sofas with high acoustic backrests improve the acoustics of the space and create a more peaceful learning environment in the middle of a larger space. Due to their wheels, the soft seats are easy to move and there is plenty of storage space under the lids.



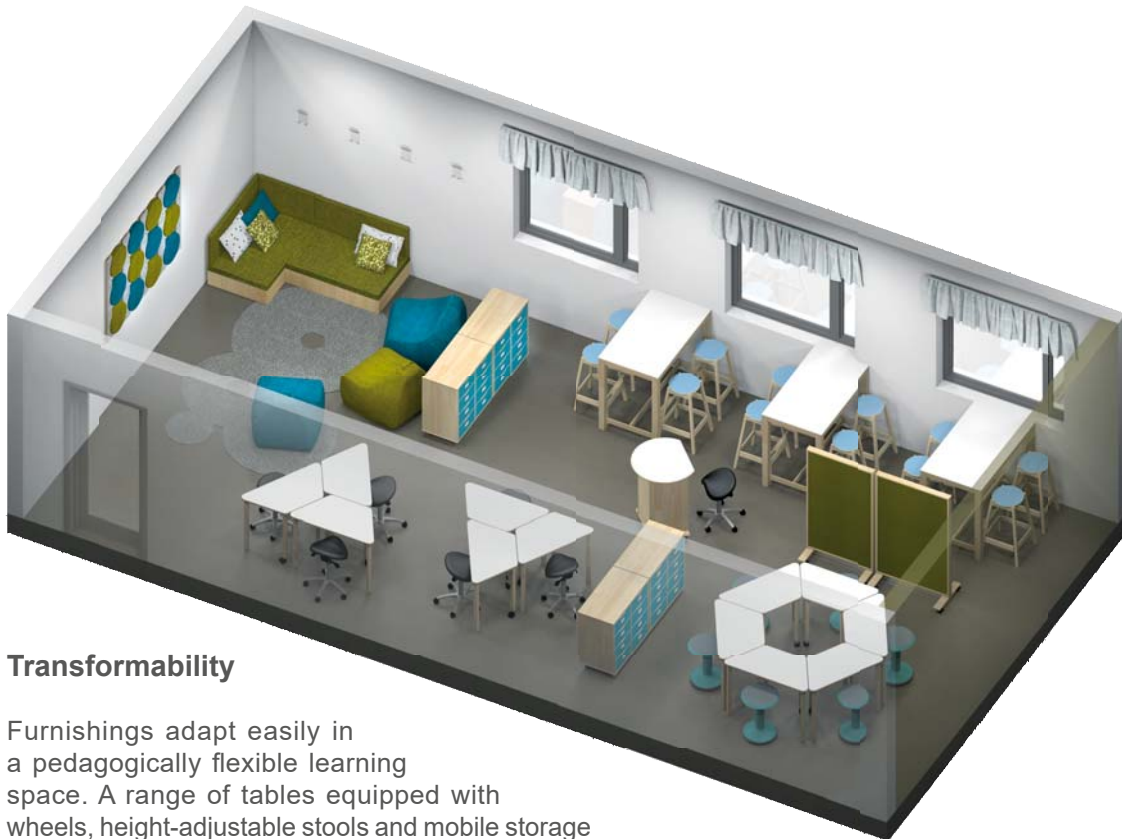

Transformability

Furnishings adapt easily in a pedagogically flexible learning space. A range of tables equipped with wheels, height-adjustable stools and mobile storage units can be used to transform a space seamlessly. Spaces can be used in different ways, enabling the use of different kinds of learning and teaching methods.



The space has high furniture, which can be used to work while standing or sitting down. Convertible tables allow work to be performed individually or in groups of different sizes. Students can retreat to work in a more relaxed area where there is soft furnishings, such as bean bags, sofas and floor cushions. The acoustics of the space have been taken into consideration in many ways. The upholstered surfaces of the cushion walls and the storage units, the soft furnishings, the carpet and the Acoustic coating on the tables all work as acoustic elements in the space. There is an easily transportable standing workstation for the teacher, which is equipped with lockable storage space.





“The colour palette for the classes has been inspired by the primary colours. This way we can teach children how different colours can be created. Two basic colour tables can be combined, and cardboard in the shade that those colours create can be added in between. The students can also be easily divided into groups of different colour. The look of the rooms give energy. The tables and the chairs can be mixed and matched according to colour palette. The cabinets act as the “sun” of the classroom during the dark winters. The teacher’s furniture is all green. The more muted greyscale palette of the bench sets makes the room calmer. The multiple colours of the drawers can be used to learn colours in different languages, for example, and they work as colourful points of focus on both sides of the classroom as well. ”

Topi Nissilä
Runko School, Piikkiö, Finland





High chair developed in cooperation with kindergartens

The High Otto chair is strong and stable. The frame is made of high-quality lacquered solid birch. The seat and the backrest comes in solid birch or birch plywood coated with high-pressure laminate. The high backrest provides optimal sitting comfort. Children and adults can easily move the Otto chair by using the hole in the back of the chair as a handle. The width of the front legs has been made as narrow as possible (380 mm) to enable the placing of the chair under the table. This also helps children to get on to the chair. The back legs are spread slightly in order to make the chair as safe as possible. When hung for storage, the Otto chair takes up minimal space and makes cleaning easy. There are no dirt-accumulating gaps in the seat or the backrest.



Detachable armrests and safety barrier



Height-adjustable footrest



Available with wide footrest



Hanging mouldings OT459





OT450

High Otto chair



OT452

High Otto chair,
with armrests



OT454

High Otto chair,
with safety barrier

Materials:

Lacquered solid birch frame, the seat and the backrest are made of solid birch or birch plywood coated with high-pressure laminate, available in primary colours. Rounded front edge of the seat. Seat height 500 mm. The legs come with screw-in anti-slip studs as standard. The chair features a footrest, which can be adjusted to three different heights. The chair can be hung under a table for storage. Width between the front legs is 380 mm.

The safety barrier and the armrests can be detached and re-attached if necessary. Screw-in filler plugs are available for the gaps left after the parts are detached.



OT456

Safety barrier



OT458

Armrests

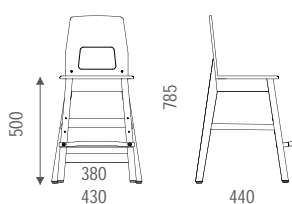

OT450

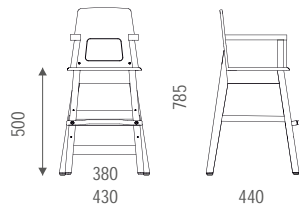

OT452

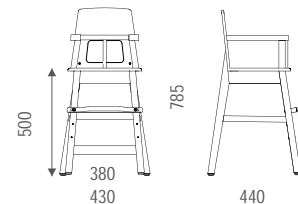

OT454



OT490 Otto school chair

Materials:

Lacquered solid birch frame, the seat and the backrest are made of lacquered solid birch or birch plywood coated with high-pressure laminate, available in primary colours. Seat height 500 mm. The legs come with screw-in anti-slip studs as standard.

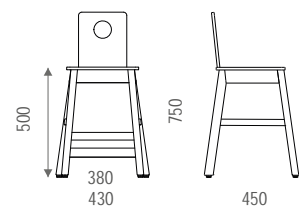

OT490





O300 Children's Onni chair



O302 Children's Onni chair, with armrests

Materials:

Lacquered solid birch frame, the seat and the backrest are made of birch plywood coated with high-pressure laminate, available in primary colours. Rounded front edge of the seat. The legs come with screw-in anti-slip studs as standard. Seat heights: 280, 350, 380 and 400 mm.



O300P Children's stackable Onni chair



O302P Children's stackable Onni chair, with armrests



Materials:

Lacquered solid birch frame, the seat and the backrest are made of birch plywood coated with high-pressure laminate, available in primary colours. Rounded front edge of the seat. The legs come with screw-in anti-slip studs as standard. Seat heights: 280, 350, 380 and 400 mm.

Child's age	Height of the chair	Height of the table
1-2 years	28 cm	46 cm
2-3 years	35 cm	57 cm
3-4 years	35 cm	60 cm
4-6 years	38 cm	60 cm
5-8 years	40 cm	63 cm

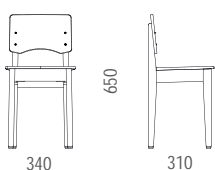

O300

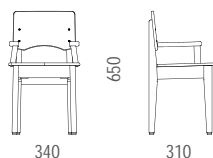

O302

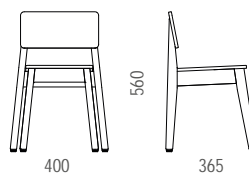

O300P

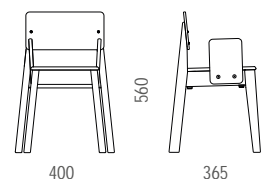

O302P





O100 Onni chair



O100P Stackable Onni chair



Materials:

Lacquered solid birch frame, the seat and the backrest are made of form-pressed plywood coated with laminate or birch veneer, available in primary colours. Can be hung underneath the table. The legs come with screw-in anti-slip studs as standard. Seat height 450 mm. The stackable Onni chair is available with row connectors.



Hanging mouldings

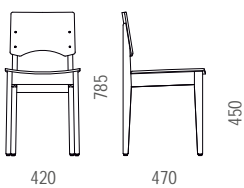

O100

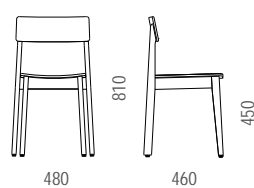

O100P





O150 Oiva-chair, laminate seat and birch veneer backrest



O152 Oiva chair, with armrests, upholstered seat and backrest



O150 Oiva-chair, upholstered seat and birch veneer back rest



O150 Oiva-chair, upholstered seat and backrest

Materials:

Lacquered solid birch frame. The seat is made of form-pressed plywood coated with laminate or birch veneer, available in primary colours. The backrest is plywood coated with birch veneer. The legs come with screw-in anti-slip studs as standard. Seat height is 450 mm. The seat and the backrest are available with upholstery. The seat is available fixed or detachable. The seat is available with moisture-proof and detachable upholstery. The backrest's upholstery is always detachable.



O154 Oiva rocking chair

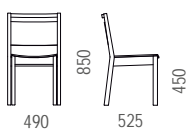

O150

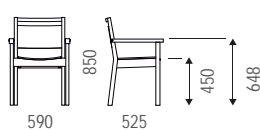

O152

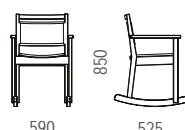

O154



Stackable, even with armrests





O105PP Stool



O105NP Stool, square seat



O106 Stool, high



O106N Stool, high, square seat

Materials:

Lacquered solid birch frame, the seat is made of birch plywood coated with high-pressure laminate, available in primary colours. The legs come with screw-in anti-slip studs as standard. Seat heights: 280, 350, 380, 400, 450 and 730 mm.

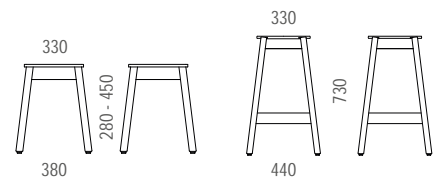

O240 High table

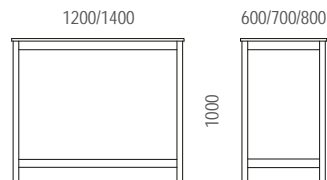

Materials:

The tabletop is made of 18 mm furniture board coated with high-pressure laminate or Acoustic-coating. The tabletop has birch coloured ABS edge trim. Available in primary colours. Lacquered solid birch legs come with screw-in anti-slip studs as standard.







Rectangle tables

L200

Laminate tabletop

L200A

Acoustic tabletop



600/700/800
900/1000/1200

600/700/800/
1200/1400/1600/1800

Semi-circular tables

L200PP

Laminate tabletop

L200PPA

Acoustic tabletop



600

1200

Parallelogram tables

L200S

Laminate tabletop

L200SA

Acoustic tabletop

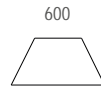

600

600

1200

Round tables

L200P

Laminate tabletop

L200PA

Acoustic tabletop



Ø700/Ø900/Ø1200

Materials:

The tabletop is made of furniture board coated with high-pressure laminate or sound-reducing Acoustic finish, available in primary colours. The thickness of the table's top is about 25 mm. Birch ABS edge trim. Lacquered solid birch legs come with screw-in anti-slip studs as standard. Table heights: 460, 520, 570, 600, 630 and 730 mm.

Tables with flange legs and plywood tabletops

Rectangle tables

R200

Laminate tabletop

R200A

Acoustic tabletop



600/700/800
900/1000/1200

600/700/800/
1200/1400/1500

Semi-circular tables

R200PP

Laminate tabletop

R200PPA

Acoustic tabletop



600

1200

Parallelogram tables

R200S

Laminate tabletop

R200SA

Acoustic tabletop

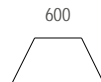

600

600

1200

Round tables

R200P

Laminate tabletop

R200PA

Acoustic tabletop



Ø700/Ø900/Ø1200

Materiaalit:

The tabletop is made of plywood coated with high-pressure laminate or sound-reducing Acoustic finish, available in primary colours. The thickness of the table's top is about 25 mm. Rounded corners. Lacquered solid birch legs come with screw-in anti-slip studs as standard. Table heights: 460, 520, 570, 600, 630 and 730 mm.



Rounded corners





Rectangle tables

S200

Laminate tabletop

S200A

Acoustic tabletop

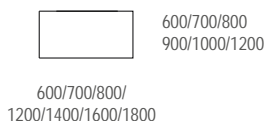

Semi-circular tables

S200PP

Laminate tabletop

S200PPA

Acoustic tabletop

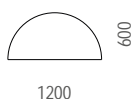

Parallelogram tables

S200S

Laminate tabletop

S200SA

Acoustic tabletop

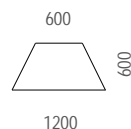

Round tables

S200P

Laminate tabletop

S200PA

Acoustic tabletop

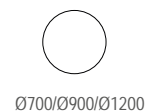

Materials:

The tabletop is made of furniture board coated with high-pressure laminate or sound-reducing Acoustic finish, available in primary colours. The thickness of the table's top is about 25 mm. Birch ABS edge trim. Lacquered solid birch legs and frame. The legs come with screw-in anti-slip studs as standard. Table heights: 630 and 730 mm.

Tables with trumpet legs



Round tables with laminate table top

P200

Furniture board with ABS edge banding

PR200

Plywood

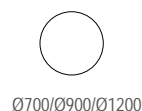

Round tables with Acoustic table top

P200A

Furniture board with ABS edge banding

PR200A

Plywood

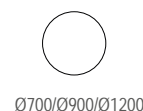

Materials:

The tabletop is made of furniture board or plywood coated with high-pressure laminate or sound-reducing Acoustic finish, available in primary colours. The thickness of the table's top is about 25 mm. Birch ABS edge trim. The basic colour of the trumpet leg is grey RAL 9006. Table heights: 460, 520, 570, 600, 630 and 730 mm.





O200 Table with laminate tabletop

O200A Table with Acoustic tabletop



O250 Table with laminate tabletop

O250A Table with Acoustic tabletop

Materials:

Lacquered solid birch frame and legs. The tabletop is made of furniture board coated with high-pressure laminate or sound-reducing Acoustic finish, available in primary colours. Birch ABS edge trim. The thickness of the O200 table's top is 18 mm and the O250 table is about 25 mm. The legs come with screw-in anti-slip studs as standard.



W700 Bench

Materials:

Lacquered solid birch frame. The seat is lacquered solid birch or furniture board coated with high-pressure laminate or sound-reducing Acoustic coating. Available in primary colours. The legs come with screw-in anti-slip studs as standard.



O255 Table with laminate tabletop

O255A Table with Acoustic tabletop

Materials:

The tabletop is made of furniture board coated with high-pressure laminate or sound-reducing Acoustic coating. The thickness of the table's top is about 25 mm. Birch ABS edge trim. Available in primary colours. Lacquered solid birch legs are partly coated with high-pressure laminate. Lockable wheels.

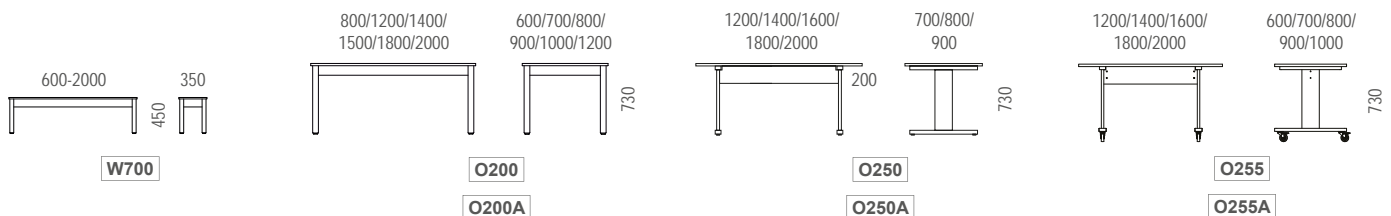



Table groups for low O300 and O300P children's Onni chairs.

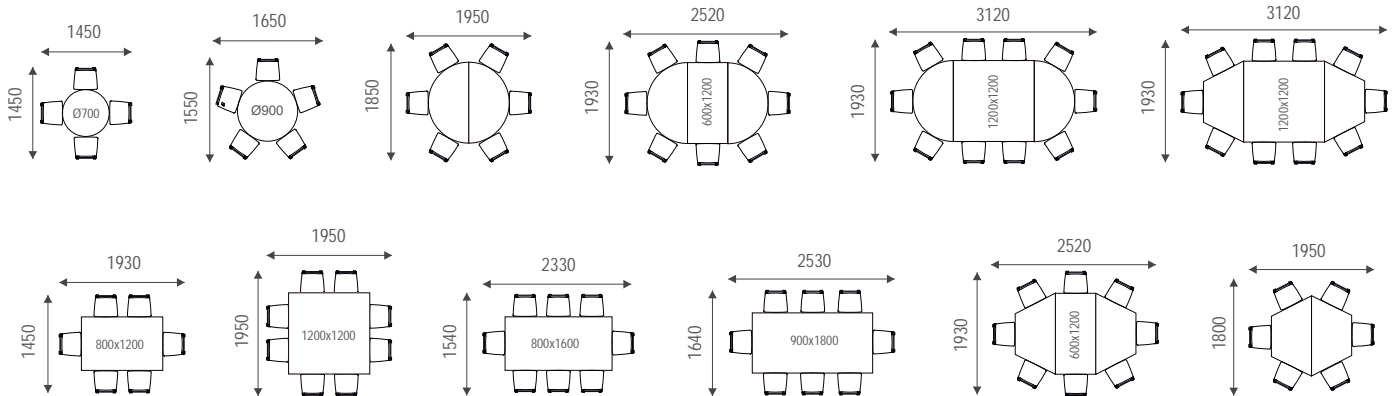
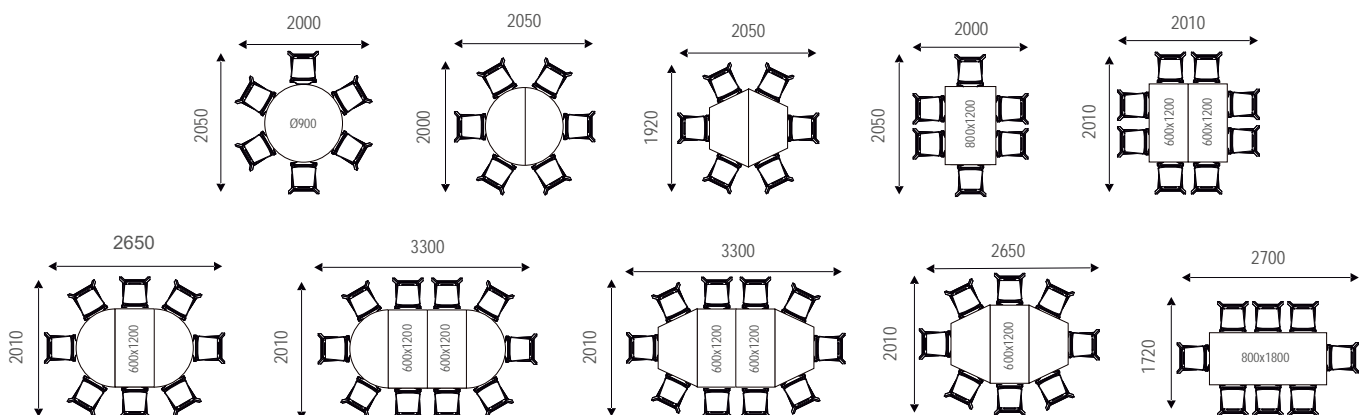
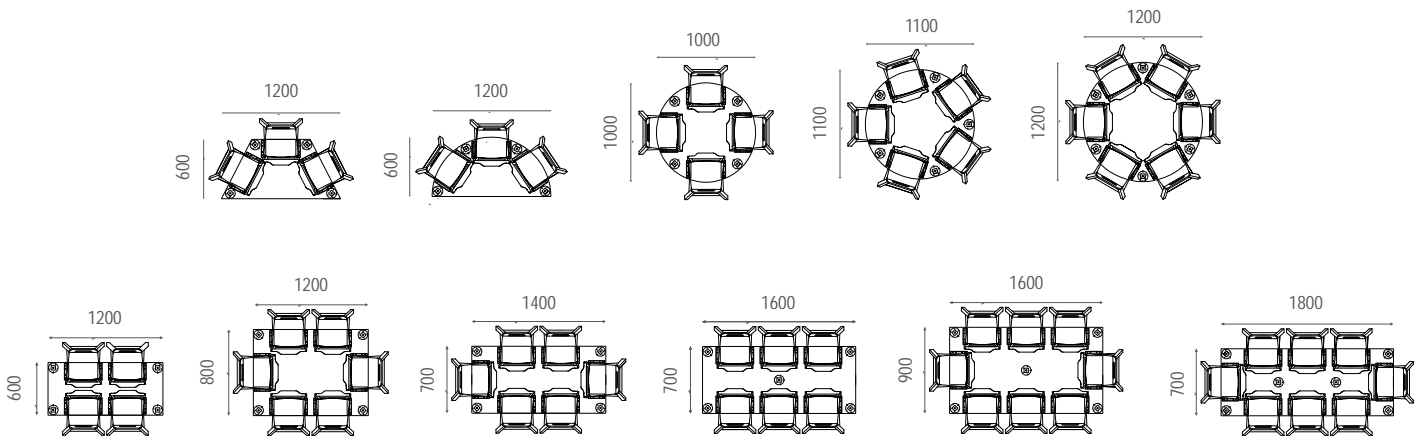

Table groups for OT450 children's High Otto chairs.





The suspension of the OT450 children's High Otto chair underneath tables with flange legs.



The suspension of the O100 adult's Onni chair underneath tables with flange legs.

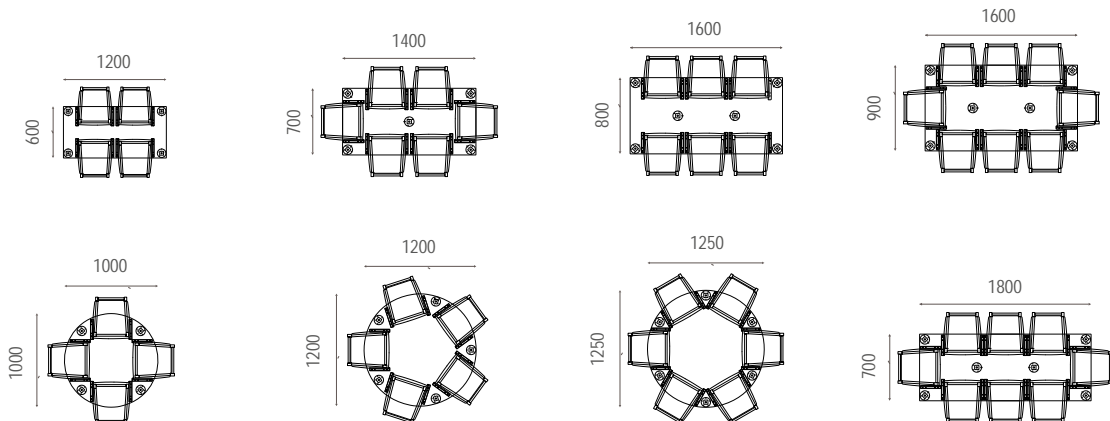

Student desks are specially designed for learning environments, and the furnishing of the space can be easily changed so that working is possible independently or in groups of different sizes. Due to the wheels, the tables are easy to move from one place to another.



Student desks can be used to form different kinds of table groups

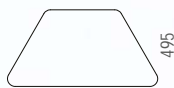
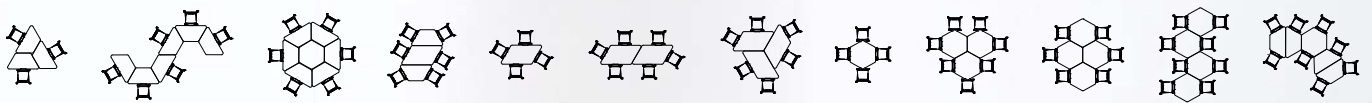

970

R200S

R200SA

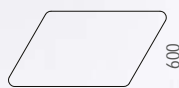

1258

R200V

R200VA

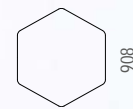

800

R200K

R200KA





R200V

Parallelogram table,
laminated tabletop

R200VA

Parallelogram table,
Acoustic tabletop



R200S

Trapezoid table,
laminated tabletop

R200SA

Trapezoid table,
Acoustic tabletop



R200K

Hexagon table,
laminated tabletop

R200KA

Hexagon table,
Acoustic tabletop

Materials:

The tabletop is made of birch plywood coated with high-pressure laminate or Acoustic coating. Rounded corners, available in primary colours. The thickness of the table's top is about 25 mm. Lacquered solid birch legs come with screw-in anti-slip studs as standard. Lockable wheels come as optional extras. Table height 730 mm.



YO200 Student desk

YO201 Basket

YO202 Screen

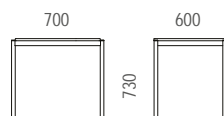

Student desk is stackable

Materials:

The frame is powder-coated steel, colour RAL7042. The tabletop is made of birch plywood coated with laminate, rounded corners, available in primary colours. The thickness of the table's top is 15 mm. Detachable steel sheet screens and a basket come as optional extras.





TT-300 Fold-out table

TT-350 Fold-out bench

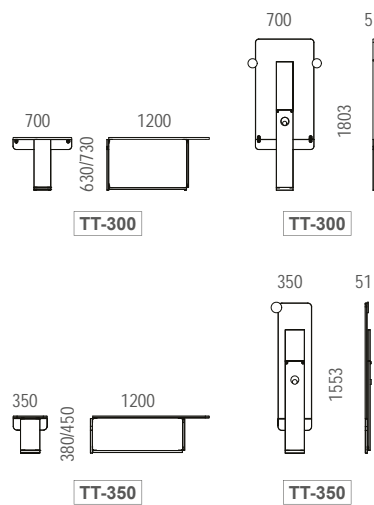

Table and benches folded up

The table and the bench can be folded upright to save space. Furniture is locked upright with safe locking mechanism. The table and the benches are sold separately.

Materials:

Lacquered birch plywood, the table and the bench tops and the locking mechanisms are coated with high-pressure laminate, available in primary colours. Screw-in anti-slip studs are attached to the bottom of the furniture and they come as standard.



WM050 Heksa table

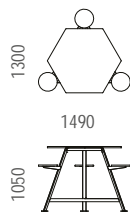

A table for group work which has three seats and three standing spaces. The table can be folded flat to save space. The tabletop works as a white board. A container for markers and a sponge is available as an optional extra.

Materials:

The tabletop is made of birch plywood coated with white board. Rounded corners. The thickness of the table's top is 20 mm. White powder-painted steel frame. Seats are upholstered with durable artificial leather. The colour of the tabletop can be changed upon special request.



OP350

Height-adjustable workstation, with front panel and drawer



OP352

Height-adjustable workstation, with front panel



OP355

Height-adjustable workstation, without front panel and drawer

Materials:

The tabletop is made of birch plywood coated with high-pressure laminate, the front panels of the drawers are laminate, primary colours. The thickness of the table's top is 20 mm. The base of the table has gas-assisted spring elevation adjustment. Lockable wheels come as standard, also available with adjustable legs. The front panel is made of furniture board coated with birch veneer. Locks for the drawer come as an optional extra.

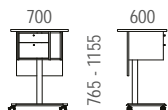

OP350

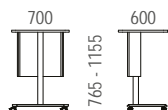

OP352



OP355



S240 Desk



SE50

Workstation



SE51

Workstation

Materials:

The tabletop and the front panels of the drawers are coated with high-pressure laminate, available in primary colours. The thickness of the table's top is about 25 mm. Lacquered solid birch legs. Birch veneer-coated front panel for the table is available as an optional extra.

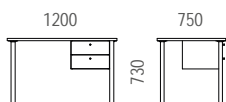

Materials:

Lacquered solid birch frame, the tabletop is plywood coated with high-pressure laminate. The thickness of the table's top is 20 mm. The front panels of the drawers are coated with laminate, available in primary colours. The top drawer is equipped with a lock. Lockable wheel.

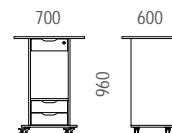



OP200 Desk, height-adjustable



OP220 Desk, height-adjustable and with a front panel



OP240 Corner table, height-adjustable



OP250 Corner table, height-adjustable



OT41L Drawer



OT41LB Drawer

Materials:

The tabletop is solid birch or furniture board coated with high-pressure laminate, available in primary colours. The thickness of the table's top is about 25 mm. The base of the table can be adjusted electrically between 705 – 1205 mm. The front panel and the screen of the O240 table are furniture board coated with birch veneer. A base with 620 – 1270 mm range comes as an optional extra.

Materials:

Lacquered solid birch frame, the front panels of the drawers are furniture board coated with high-pressure laminate, available in primary colours. Lockable wheels. Locks come as an optional extra.



OT41L



OT41LB

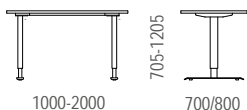

OP200

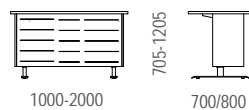

OP220

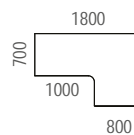

OP250-V

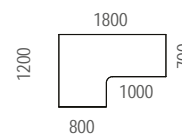

OP250-O

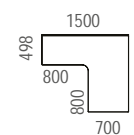

OP240-V

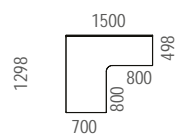

OP240-O





A142 Mechanics chair,
seat Ø360 mm

Materials:

The seat is polyurethane; the diameter of the seat is 360 mm. Can be height-adjusted with a gas-assisted spring, seat height 370 – 500 mm. Metallic five-pointed swivel base with wheels, Ø 75 mm rubber wheels. Metallic equipment basket.



S 480 - 610 mm
M 580 - 800 mm
L 620 - 880 mm

A141 Saddle chair,
seat L 320 mm, S 340 mm



S 460 - 600 mm
M 540 - 740 mm
L 630 - 860 mm

A144 Saddle chair,
seat L 410 mm, S 350 mm

Materials:

The saddle is genuine leather; the seat height can be adjusted with a gas-assisted spring. Size M height adjustment gas-assisted spring comes as standard. Seat angle adjustment. Metallic five-pointed swivel base with wheels, the diameter of the swivel is 480 mm. Ø 75 mm wheels, which roll better, and S and L height adjustment springs come as optional extras.



OL41L Drawer



OL610 Cabin



OL7200 Cabin



OL140000 Cabin

Materials:

The frame, doors and the front panels of the drawers are made of white furniture board as standard. Primary colours are available for the frame, the doors and the drawers as a supplementary order. Metallic handles and, locks come as optional extras. Available with base or legs, lower models also available with lockable wheels.



OL41L

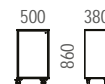

OL610

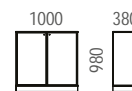

OL7200

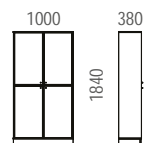

OL140000





Otto storage systems can be modified according to use. Every module can be fitted with drawers, shelves or doors. Otto storage systems come in different sizes and the drawers come in three different heights. Otto and N series boxes can be used in open compartments and behind the doors. Ask our sales team about the different options available.



OTE62PP



OTE62DD



OT72AL

+ 1 x N1 box
+ 1 x N3 box



OT72AAA

+ 4 x OT120
+ 1 x additional shelf



OT63KKK

Materials:

Lacquered solid birch frame. The doors and front panels of the drawers are made of furniture board coated with laminate. Available in primary colours. Also available with laminate or furniture board frame or top. Height-adjustable shelves. Otto storage systems are delivered with wheels, base or solid birch legs. The back panel is birch plywood as standard.

Safety drawer, closes easily



The bases of the drawers are equipped with felt gliders to prevent the drawer from scratching surfaces.



Option for the back panel:

The back panel of the Otto storage units is birch plywood as standard. The back panels can be upholstered or fitted with acoustic felt, magnetic whiteboard, chalk board or bulletin board.



- OTAH**

Lacquered birch plywood
- OTAK**

Acoustic felt
- OTAA**

Acoustic fabric
- OTTT**

White board
- OTMT**

Magnetic white board
- OTML**

Magnetic chalk board
- OTBB**

Bulletin board

Options for legs:

Otto storage systems are delivered with wheels, base or solid birch legs.



Lockable wheels



Base



Lacquered solid birch legs

Accessories:



Metallic nameplates



Support baseboard for the wheels



Hooks for bags, locks



Additional shelf

Boxes:

Otto boxes are made of birch plywood coated with white high-pressure laminate. The colour of the front panels can be chosen from the primary colour range. Colours for N1 and N2 plastic boxes. N3 is only available in the Translucent 020 colourway.



Otto boxes OT120 and OT121



OT120



OT121

- 020 Translucent
- 002 Sunshine Yellow
- 022 Pale Blue
- 001 Tropical Orange
- 023 Pale Green
- 019 Light Grey
- 015 Charcoal Grey

- 75
- N1**
- 150
- N2**
- 300
- N3**



OT62AA



OT62AO



OT62OO



OTE62DD



OT62AL



OT62LL



OT62OL



OTE62DL



OTE62AP



OTE62PP



OTE62OP



OTE62PD



OT62AK



OT62KK



OT62OK



OT62KL



OT52AA + OT52AA



OT52OO + OT52AA



OT52LL + OT54A



OT92AA + WL011



The depth of the Otto modules is 420 mm.

	477	477	800	800	800	800	1183	1183	1183	1183	1183	
385	OT21A	OT21O OT21K	OT21AA	OT22AO OT22AK	OT22OO OT22KK	OT22LO OT22LK	OT23AAA	OT23AAO OT23AAK	OT23OAO OT23KAK OT23KAO	OT23OOO OT23KKK	OT23OLO OT23KLK	385
385	OT21L		OT22AL	OT22LL				OT23AAL	OT23LAL	OT23LLL		385
620	OT41A	OT41O	OT42AA	OT42KO OT42AO	OT42OO	OT42LO OT42LL OT42KK	OT43AAA	OT43AAO	OT43OAO	OT43OOO	OT43OLO	620
620	OT41L	OT41K	OT41LA	OT42LO OT42LL OT42KK	OT42LO OT42LL OT42KK	OT43AAL	OT43LAL	OT43LLL	OT43LLO	OT43LLO	OT43LAO	620
			OT44A	OT42AK			OT43KKO	OT43AAK	OT43KAK	OT43KKK	OT45AA	620
740	OT51A	OT51L	OT52LL	OT52LA	OT52OO	OT52AA	OT53LLL	OT53OOO	OT53AAA	OT53AAL	OT53AAO	740
740	OT51O		OT54A	OT52LO OT52AO	OT52LO OT52AO		OT53LAO	OT53OAO	OT53OLO	OT53LAL	OT55AA	740
860	OT61A	OT61O	OT62AO	OT64A	OT62OO	OTE62DD	OT63AAA	OT63AAO	OT63OAO	OT63OOO	OTE63DDD	860
860	OTE61D	OT61L	OT61L	OT62LA	OT62LL	OT62AK	OT63AAL	OT63LAL	OT63LLL	OT63OLO	OT63LLO	860
860	OT61K	OTE61P	OTE62AP	OTE62PO	OTE62PP	OT62AA	OTE63AAP	OTE63PAP	OTE63PPP	OTE63OPO	OTE63PPO	860
			OT62KO	OT62KK			OT63AAK	OT63KAK	OT63KKK	OT63OKO	OT65AA	860
980	OT71A	OT71L	OT72L	OT72LA	OT72OO	OT72AA	OT73LLL	OT73OOO	OT73AAA	OT73AAL	OT73AAO	980
980	OT71O		OT74A	OT72AO OT72LO	OT72AO OT72LO		OT73LAO	OT73OAO	OT73OLO	OT73LAL	OT75AA	980
1100	OT81A	OT81L	OT82LA	OT82LL	OT82LO	OT82OO	OT83KK	OT83AAL	OT83LAL	OT83LLL	OT83OLO	1100
1100	OT81O	OT81K	OT82AA	OT82KO OT82KK	OT82KO OT82KK	OT82KA		OT83AAK	OT83KAK	OT83KKK	OT83OKO	1100
			OT52AA + OT52AA	OT52OO + OT52AA	OT52LL + OT54A		OT92AA	OT93AAA				

Please ask our sales for more information if necessary.





OTK32

Curved Otto storage unit



OTK33

Curved Otto storage unit



OTK35

Curved Otto storage unit



OTK42

Curved Otto storage unit



OTK43

Curved Otto storage unit



OTK45

Curved Otto storage unit

Materials:

Lacquered solid birch frame. Lockable wheels. Height-adjustable shelves.

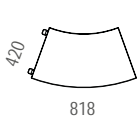

818

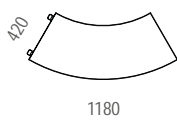

1180

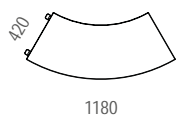

1180

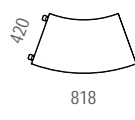

818

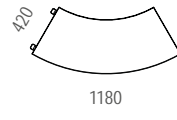

1180

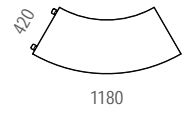

1180



505



505

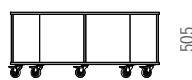

505



625

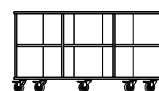

625

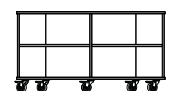

625

OTK32

OTK33

OTK35

OTK42

OTK43

OTK45





V220

High acoustic back screen for the Otto storage unit



V210

Screen with legs



V215

Screen with a white board



V240

Screen with hooks for bags

V211

Screen with wheels

Screens can be used as room dividers and they work as acoustic elements. Paper can be attached to the screens with pins. Acoustic back screen comes as an optional extra for Otto storage units with two or three compartments. The screen is available with lockable wheels or legs.

Materials:

The frame is made of lacquered solid birch, acoustic boards are made of acoustic felt as standard. Acoustic boards are available upholstered with felt fabric as a supplementary order. The wheels are lockable.



V230

Acoustic board, wall-mounted

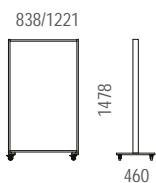

V211

V215

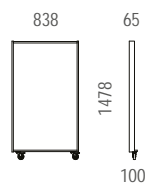

V220

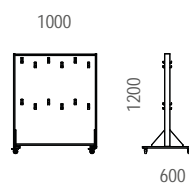

V240

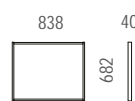

V230

Acoustic felt



AH01
White



AH02
Light grey



AH03
Dark grey





OS82LO
+ 8 x N1 box



OS82LO
+ 4 x N1 box and
1 x N3 box



OS81L
+ 8 x N1 box

Materials:

Lacquered solid birch frame, the back panels are made of veneer-coated furniture board as standard. Also available with laminate or furniture board frame or top. Height-adjustable shelves. Plastic boxes are available in three heights: N1 75, N2 150 and N3 300 mm. The width of the boxes is 312 mm and the depth is 377 mm. Osku storage units are available with wheels, base or legs. The back of the Osku modules can be upholstered or fitted with magnetic whiteboard, chalk board or bulletin board. Locks come as optional extras.



Magnetic white board



The boxes can be placed behind the door

Colours for N1 and N2 plastic boxes. N3 is only available in Translucent 020 material.

	020 Translucent							
	002 Sunshine Yellow							
	022 Pale Blue							
	001 Tropical Orange		75	150	300			
	023 Pale Green		312	312	312			
	019 Light Grey		377	377	377			
	015 Charcoal Grey		N1	N2	N3			



The depth of the Osku modules is 420 mm.

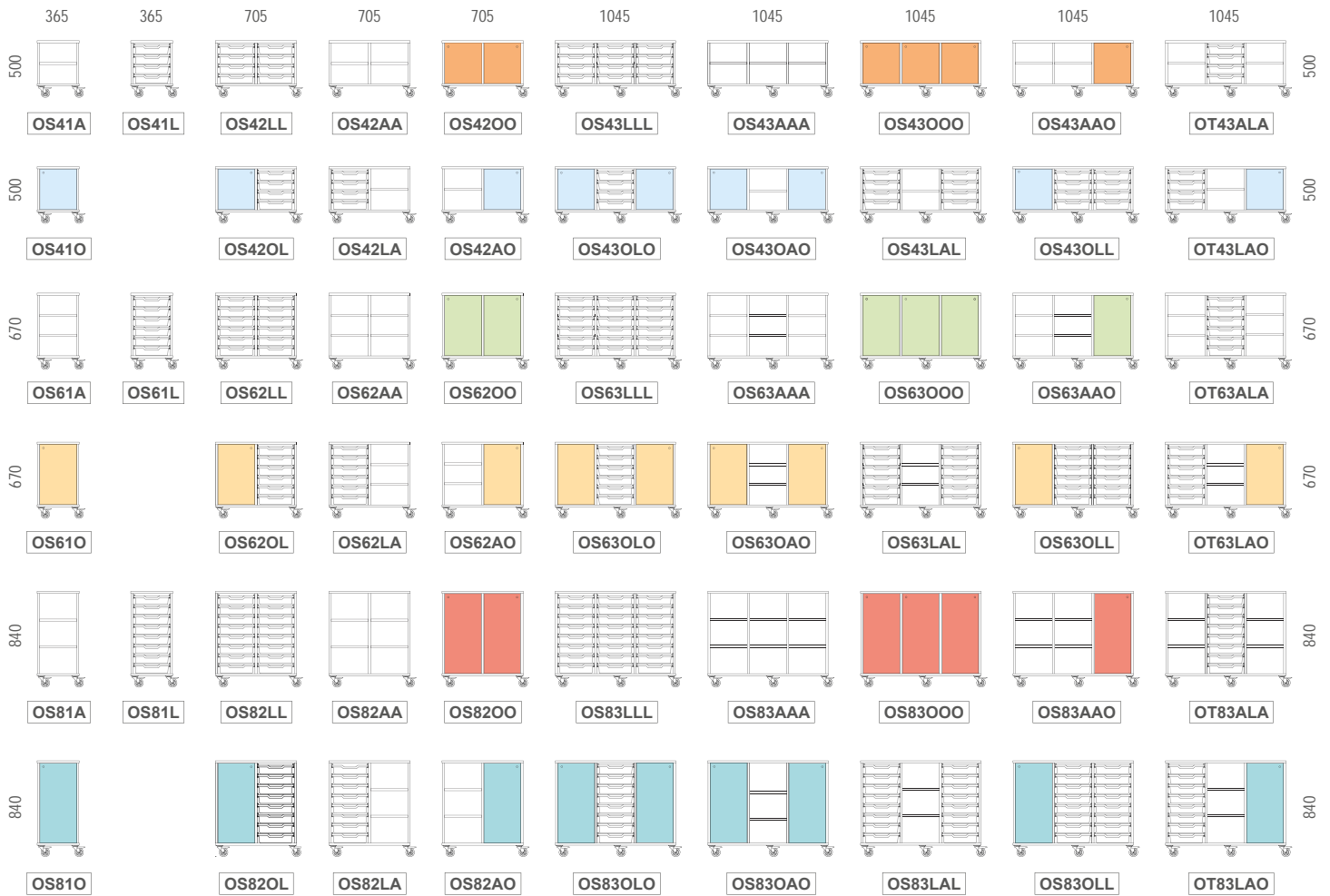

The Osku storage system can be customised to suit the needs of the customer. Every module can be equipped with plastic boxes (L), open shelves (A) or a door (O). The shelves are height-adjustable. The plastic boxes can be placed behind the doors.



OST8200 Charging station for tablets



NT-10

Box for charging tablets

The charging station can be used to charge tablets and other mobile devices. NT-10 plastic boxes have been equipped with USB outlets, which are used to charge devices. One box has outlets for 10 tablets; the device's power lead is used for charging. A synchronising feature is available as an optional extra.

Materials:

Lacquered solid birch frame, doors are made of furniture board coated with high-pressure laminate. Primary colours. Lockable wheels and doors, inlets for power leads. One charging station can accommodate 4 four NT-10 boxes, which are available as optional extras.

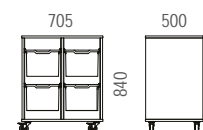

OST8200





ON32AA + 3 x OT120



ON33AAA



ON33AAA + 6 x OT120



ON32AA + 4 x N2



ON33AAA + 9 x N2



ON33AAA + 6 x OT120



ON42AA + 8 x N2



ON43AAA



ON43AAA + 12 x OT120

Materials:

Lacquered solid birch frame, height-adjustable shelves. Onni storage units are available with wheels, a base or legs. OT120 Otto boxes and N2 plastic boxes come as optional extras.

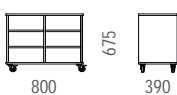

ON32AA

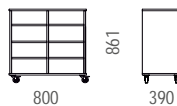

ON42AA



ON33AAA



ON43AAA

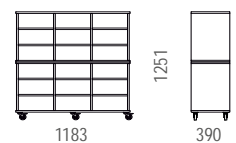

ON33AAA + ON33AAA





M200

Wall shelf



M201

Wall shelf



M61

Wall shelf



M610

Wall shelf



M62VV

Showcase,
wall-mounted

Materials:

Lacquered solid birch frame, height-adjustable shelves. The backs of the shelves are made of birch plywood, also available with doors. The M200 and M201 models do not have backs. Locks for the doors are available as optional extras.



M62 Wall shelf



M63 Wall shelf

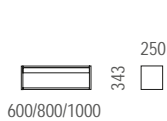

M200

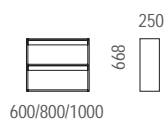

M201



M61



M610



M62VV



M62

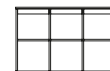

M63

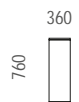

M100 Wall shelf

Materials:

Lacquered solid birch.

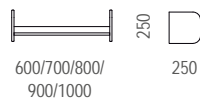

M101 Wall shelf

Materials:

Lacquered solid birch.

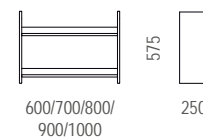



V126

Children's book trolley



V127

Children's book trolley,
single-sided



V128

Children's book trolley,
low



V122

Book trolley,
double-sided



V122B

Children's book trolley,
single-sided



V129

Children's book trolley,
double-sided

Materials:

The frame is made of lacquered solid birch or white laminate with birch ABS edge trim. Lockable wheels, aluminium handles.



V150 Bookshelf,
double-sided



V155 Bookshelf,
double-sided



V156 Bookshelf,
double-sided,
inclined shelves
on the top

Materials:

The frame and the shelves are made of lacquered solid birch, the partition wall is furniture board coated with high-pressure laminate, available in primary colours. Lockable wheels. Aluminium handles.





V120
Equipment carrier



V121
Serving trolley



V123
Trolley

Materials:

The frame is made of lacquered solid birch or white laminate with birch ABS edge trim. Lockable wheels, aluminium handles.



VV52 Growing trolley



VV01 Growing box

Materials:

Lacquered sold birch frame, lockable wheels. The trolley has two 360 x 360 x 300 mm pots with water container, while the box has one. The pots are made of 100 % recycled plastic.

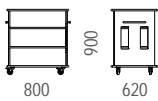

V150

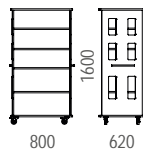

V155

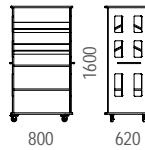

V156

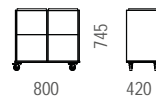

VV52

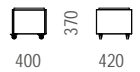

VV01

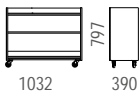

V120

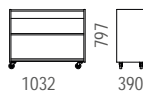

V121

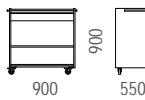

V123

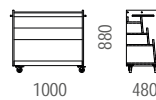

V129

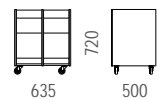

V126

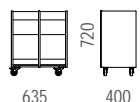

V127



V128

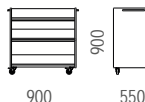

V122

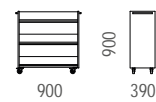

V122B





LE101 Toy box



LE103 Toy box with a lid



LE110 Trolley for building blocks

Materials:

Lacquered solid birch frame, birch plywood bottom, wheels. The lid comes with safety hinges and is birch plywood coated with high-pressure laminate. Primary colours. Lockable wheels come as optional extras.



IR20-3 Bench, three compartments

IRP20-3 Bench padding

LE111 Toy box



IR20-2 Bench, two compartments

IRP20-2 Bench padding

LE114 Toy box with plexiglas

Materials:

Lacquered solid birch frame. The benches have height-adjustable studs. The boxes are equipped with wheels. The toy boxes and the padding come as optional extras. Lockable wheels for the toy boxes come as optional extras.

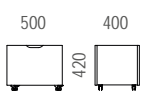

LE101

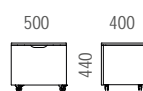

LE103



LE110

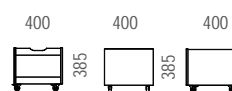

LE114

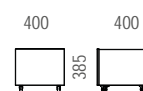

LE111

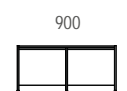

IR20-2

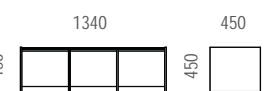

IR20-3





OTRP-2

Otto activity table,
+ 2 x OT121



OTRP-3

Otto activity table,
+ 4 x OT121



OSRP-2

Osku activity table,
+ 8 x N1 box
+ 4 x N2 box



OSRP

Osku activity table,
+ 8 x N1 and N2 box + 2 x N3 box

Materials:

Double-sided. Lacquered solid birch frame. The tabletop is coated with sound-reducing Acoustic finish and bordered with edges. The front panels of the drawers are made of furniture board coated with high-pressure laminate, available in primary colours. Lockable wheels. Plastic boxes for the Osku activity table are available in three heights: **N1 75, N2 150 and N3 300 mm**. The width of the boxes is 312 mm and the depth is 377 mm. OT121 Otto boxes are also available as optional extras.

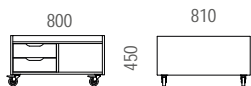

OTRP-2



OTRP-3

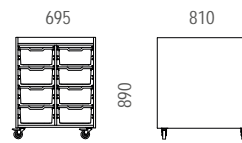

OSRP

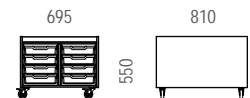

OSRP-2



OTP-1208 Examination table

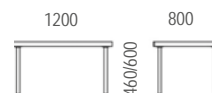

Materials:

Lacquered solid birch sides and legs, the tabletop is birch plywood coated with high-pressure laminate. Primary colours. The legs come with screw-in anti-slip studs as standard.



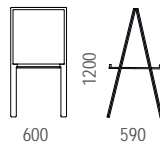

V140 Drawing stand

Materials:

Birch plywood coated with white high-pressure laminate. Foldable, with four clips for attaching paintings included.

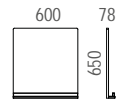

V141 Drawing stand, wall-mounted

Materials:

Birch plywood coated with white high-pressure laminate. Two clips for attaching paintings included.



K620 Drawer for sketches, 10 drawers, size A1



K620-8 Drawer for sketches, 8 drawers, size A1



K625-9 Drawer for sketches, 9 drawers, size A2

K620-A0 Drawer for sketches, 10 drawers, size A0

Materials:

Lacquered solid birch top and bottom, birch veneer-coated furniture board sides, birch plywood back. Ten drawers with stainless steel rails. Stainless steel knobs. The front panels of the drawers are coated with birch veneer or high-pressure laminate. Available in primary colours. The drawer is available with a base, lockable wheels or legs.

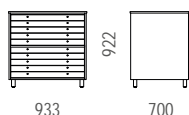

K620

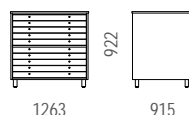

K620-A0

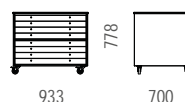

K620-8

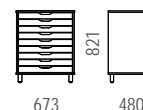

K625-9



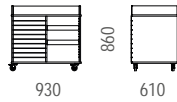

V160 Material trolley, double-sided

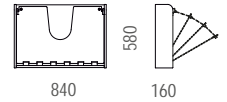

V145 Cardboard stand

Materials:

Lacquered solid birch frame, furniture board pull-out shelves (size 438 x 300 mm) for paper storage (9 + 9 pcs) accessible from both sides of the trolley. Pull-out shelves with front edges on both sides of the cart. There are compartments on top of the trolley with movable partition walls, 10 pcs. The trolley is available with wheels, base or legs.

Materials:

Lacquered solid birch frame, the surfaces are lacquered birch plywood. Designed to be hung on a wall. Size A2.



V132-13
Drying carrier, 13 shelves



V132-25
Drying carrier, 25 shelves



V132-35
Drying carrier, 35 shelves

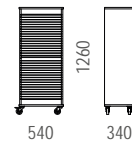

V133
Additional shelf

Materials:

Lacquered solid birch frame. Moisture-proof furniture board shelves for drying. Lockable wheels. The carrier can be used from both sides.



S701A Bench set for children



S701B Bench set for children

Materials:

Lacquered solid birch frame, the seat is made of lacquered solid birch or furniture board coated with high-pressure laminate or sound-reducing Acoustic coating. Available in primary colours. The legs come with screw-in anti-slip studs as standard.

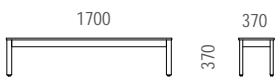

S701-1B

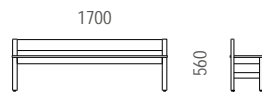

S701-1A

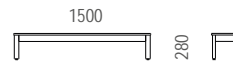

S701-2

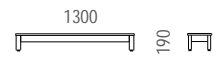

S701-3



KK150 Bench set

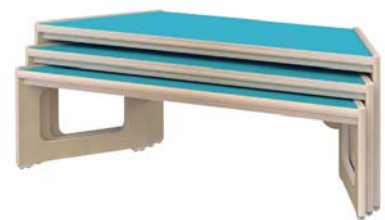
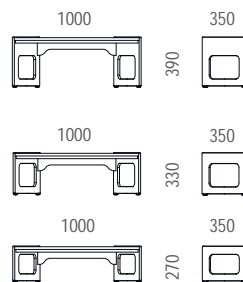

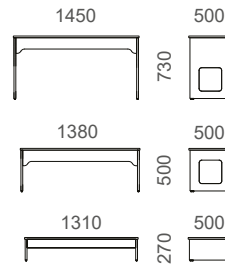

Table and bench

KK100 Stand bench set/Board set

The stand can also be used as a bench or table. The benches can also be used for exercise as children can crawl through the holes at the ends of the bigger benches.

Materials:

Lacquered birch plywood frame, the bench tops are made of birch plywood coated with high-pressure laminate. Available in primary colours. Comes with screw-in anti-slip studs as standard. Cushions are available as optional extras.

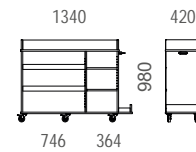

OTSTV Musician's trolley

Materials:

Lacquered solid birch frame. There is a compartment with seven movable dividers on top. Height-adjustable shelves, and pull-out shelves with front edges, two pcs each. Cushioned spot at the end of the cart for a guitar or other instrument. Lockable wheels. OT120 Otto boxes are available as optional extras.



LK26 Stage

Materials:

Lacquered solid birch frame, the top is made of furniture board coated with Acoustic coating. Primary colours. There are screw-in anti-slip studs under the base.



AS20 Cajon stool

Materials:

Lacquered birch plywood frame, screw-in anti-slip studs as standard. Seat height is 450 mm. The padding is upholstered with Inari fabric as standard, thickness 50 mm. Also available with different upholstery options as a supplementary order.



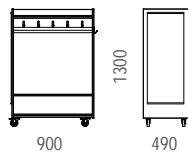

V170 Role play trolley

Materials:

Lacquered solid birch frame, lockable wheels. A rail for hangers and hooks for clothing. There is a safety glass mirror at the end of the trolley and four hooks at the other end.

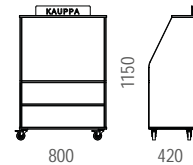

LK10 Shop/puppet theatre

Materials:

Lacquered solid birch frame, with a rail for hangers and hooks for clothing. There is a sign on the top. Lockable wheels. A shelf at the front and back. The sign is birch plywood coated with white laminate,; one side reads "Shop" and the other "Theatre". The furniture can be used as a shop or a puppet theatre. A rail for curtains and the curtains come as optional extras.

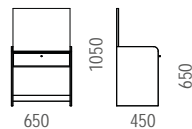

S230 Hairdresser table

Materials:

Lacquered solid birch frame, the front panel of the drawer is furniture board coated with high-pressure laminate,; primary colours. Safety glass mirror.



LK12 Stand for puppets

Materials:

Lacquered solid birch, chrome steel pipes for the puppets. The stand can fit 10 puppets. It can be assembled on top of the Otto storage unit and the V150 book shelf.





LK1
Fridge



LK2
Sink unit



LK3
Dishwasher



LK4
Washing machine



LK5
Stove



LK6 Play kitchen

Materials:

Lacquered solid birch frame. The top and the doors are coated with white, the background for the knobs are coated in yellow, and the knobs and stove surfaces are coated in grey laminate. Plastic basin in the sink cabinet. Aluminium handles. There are height-adjustable shelves at the back of the play kitchen island and it is equipped with lockable wheels.

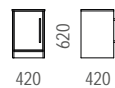

LK1

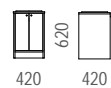

LK2

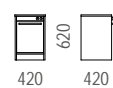

LK3

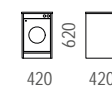

LK4



LK5



LK6

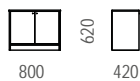

LK7

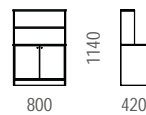

LK8

LK7 Cabinet for playing house

LK8 Cabinet for playing house with an open shelf

Materials:

Lacquered solid birch frame, the doors and the top are made of furniture board coated with white high-pressure laminate. Aluminium handles. There are shelves behind the doors.

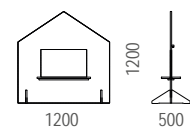

LK11 Play wall

Materials:

The wall is made of birch plywood coated with high-pressure laminate. Primary colours. The tabletop and the legs are made of lacquered solid birch. The legs come with screw-in anti-slip studs as standard. A rail for curtains and the curtains come as optional extras.

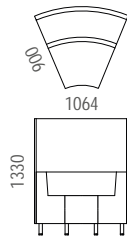

SM10 Sofa module

A sofa consisting of five lobby sofa modules

Lobby sofa modules can be used to create sofa groupings of different sizes. There are seats in two different heights. The high backrest works as an acoustic element.

Materials:

Durable frame, padded seat and backrest. Seat heights 450 and 720 mm. Height-adjustable steel tube legs. There is a wide selection of upholstery fabrics available.

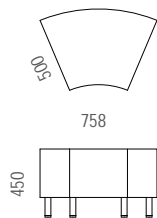

A sofa consisting of four seat modules

SM20 Curved seat module

Materials:

Durable frame, padded seat. Seat height 450 mm. Height-adjustable steel tube legs. There is a wide selection of upholstery fabrics available.



OT23KAK Otto bench

OTP2 Padding, for a bench with two compartments

OTP3 Padding, for a bench with three compartments

Materials:

The frame is made of lacquered solid birch, available with two or three compartments. Compartments can be open or have a door or, a drawer. Padding for the bench comes as an optional extra, thickness 45 mm. There is a wide selection of upholstery fabrics available. Lockable wheels.





IR10 Seat stool, rectangle



IR15 Seat stool, trapezoid



Materials:

Lacquered solid birch frame, comes with birch legs or lockable wheels. The thickness of the padding is 45 mm. There is a wide selection of upholstery fabrics available. Safety hinges. There is storage space inside the stools.

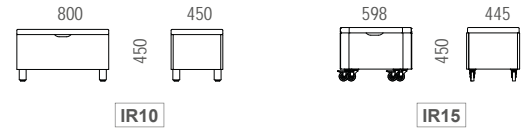

MS100 Sofa module

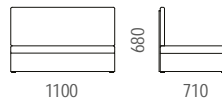

MS105 Backrest padding for the corner

A sofa consisting of two MS100 sofa modules and one MS105 back rest padding.

Materials:

Lacquered solid birch base, foam rubber cushions. There is a plywood board behind the backrest. The upholstery is detachable and it has been fitted with a zip. The standard upholstery fabric is Inari. There is a wide selection of other upholstery fabrics available as a supplementary order. The thickness of the padding for the seat is 80 mm, and for the backrest 45 mm. The base comes with screw-in anti-slip studs as standard. Seat height 280 mm.



S501 + S505 + S506 Sofa-bed

P314 Backrest padding, 300 x 1400 mm, thickness 60 / 120 mm

P5514-8 Padding for a bench, 80 x 550 x 1400 mm

P5513 Mattress for side bed, 50 x 550 x 1300 mm

P5512 Mattress for side box, 50 x 550 x 1200 mm

Materials:

Lacquered solid birch frame, birch plywood bottom with holes for ventilation. Foam rubber mattresses and paddings with detachable and water-washable upholstery. Mattress for side bed and for side box and paddings for sofa-bed as optional extras. Sofa-bed paddings available upholstered with Inari-fabric as standard. There is a wide selection of other upholstery fabrics available as a supplementary order.

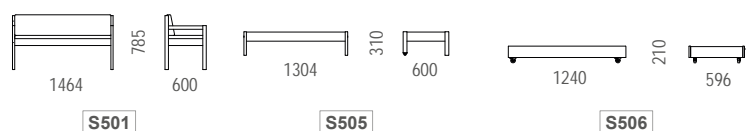



JEN-1

Jenny armchair



JEN-2

Jenny sofa,
two-seat



JEN-3

Jenny sofa,
three-seat



JEN-4

Jenny rocking chair



OLV-1

Olavi armchair



OLV-2

Olavi sofa,
two-seat



OLV-3

Olavi sofa,
three-seat



OLV-4

Olavi rocking chair

Materials:

Sturdy lacquered solid birch frame, seat height 480 mm. Headrest is available as an optional extra for the sofas and armchairs. There is a wide selection of other upholstery fabrics available.

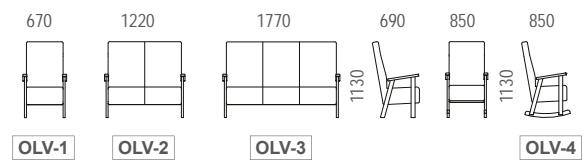
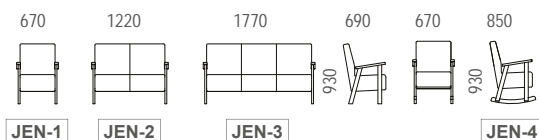



OTTO-1

Otto armchair



OTTO-2

Otto sofa, two-seat



OTTO-3

Otto sofa, three-seat

Materials:

Lacquered solid birch legs, around upholstered frame. The seat and the backrest have reversible cushions, and are fitted with a zip.

Measurements:

Width: 805 mm
Height: 850 mm
Depth: 800 mm

OTTO-1

Width: 1350 mm
Height: 850 mm
Depth: 800 mm

OTTO-2

Width: 1895 mm
Height: 850 mm
Depth: 800 mm

OTTO-3



Ø 600/700/800



O270

O270

Coffee table



450/600/1100



O260

O260

Coffee table

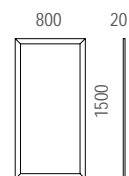

PE1508 Mirror

Materials:

Lacquered solid birch legs and frame. The tabletop is made of lacquered solid birch or furniture board coated with high-pressure laminate. Primary colours. Table heights 400/450/500 mm. The legs are equipped with screw-in anti-slip studs as standard.

Materials:

The frame is lacquered solid birch. Safety glass mirror.





W217-PP1

Soft seat,
600 x 600 x 400 mm



W217-PP2

Soft seat,
600 x 600 x 200 mm



W217-PP3

Soft seat,
800 x 600 x 200 mm



W217-PP4

Soft seat,
Ø 450 mm, K 450 mm



Soft seats can be used to create relaxed seating groups.

Materials:

Detachable cover is fitted with a zip and it can be easily wiped clean. Separate interior bag filled with polystyrene pellets. Beanbags can be upholstered with Inari fabric or artificial leather.



W217-PTV Cart for floor cushions

W217-PT Round floor cushion, Ø 350 mm, H 50 mm

Materials:

Birch plywood coated with white high-pressure laminate, lacquered solid birch. Lockable wheels. The rack can hold 12 cushions, which are available as optional extras. Interior is foam rubber E23, detachable and water-washable.

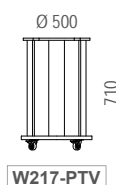

W217-PTV



W217-LTS9 Cushion wall, for nine cushions

W217-LTS12 Cushion wall, for twelve cushions

Materials:

Upright parts are plywood coated with felt, which are attached together. Colour options for the frame are white, light grey and dark grey. Cushion wall works as an acoustic element. Cushions for the wall come as optional extras.

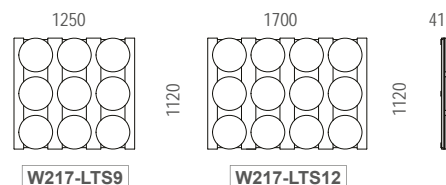

W217-LTS9

W217-LTS12



W217-1 Bean bag,
1400 x 1200 mm



W217-P Bean bag,
800 x 800 x 800 mm



W217-G Bean bag,
750 x 750 x 600 mm

W217-2 Bean bag,
1400 x 1800 mm

W217-3 Bean bag,
1000 x 800 mm



W217-B Seat, Ø 350 mm, H 160 mm



W217-S Bean bag,
1000 x 800 x 900 mm



W217-S2 Bean bag,
1450 x 1000 x 900 mm

W217-KL Rocking base



W217-4 Soft seat,
Ø 450 mm, K 300 mm



W217-T Bean bag,
1150 x 700 x 800 mm



W217-R Bean bag,
1300 x 1000 x 800 mm

Materials:

Detachable cover is fitted with a zip and it can be easily wiped clean. Separate interior bag filled with polystyrene pellets. Bean bags can be upholstered with Inari fabric or artificial leather.

Inari fabric



100 % polyester, breathable, fire safe EN 1021 P1&2 / SL1&2, can be wiped clean. The abrasion resistance of the fabric is 100, 000 Martindale.

Artificial leather



Water resistant, hygienic, can be wiped clean. The abrasion resistance of the fabric is 120, 000 Martindale.





AS11

Sensory wall,
spiral



AS12

Sensory wall,
labyrinth



AS13

Sensory wall,
balls



AS14

Sensory wall,
instrument

Materials:

Solid birch sensory walls. The boards are attached to the wall with aluminium rails. The order of the boards can be changed easily. The rails can be assembled horizontally. When the boards are assembled next to each other, they have shared rails.

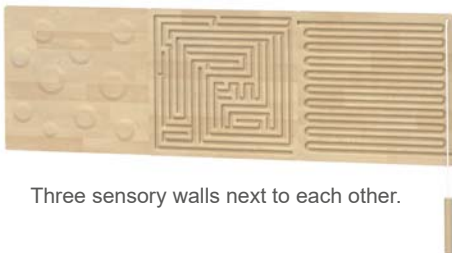

Three sensory walls next to each other.



AS11

400



AS12

400



AS13

400



AS14

32

400



AS1 Sensory seal

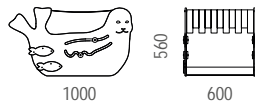

AS2 Play boat

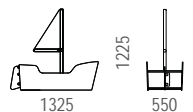

Materials:

The sides and the base are made of birch plywood coated with white laminate. The sides of the base are lacquered solid birch. The cushion and the seaweed on top are upholstered with Enstex fabric. The cover is detachable. The Sensory seal has movable parts on both sides.

Materials:

The frame is made of birch plywood coated with white laminate. Lacquered solid birch seats and mast. The sail is made of cloth.



LK80A

Soft building blocks



LK80B

Soft building blocks

Materials:

Interior is foam rubber E23. Detachable, durable and water-washable Enstex upholstery, which can be washed at 60 °C. Made in Finland.

8-piece set includes

2x 200 x 200 x 200 2x 400 x 200 x 200 1x 400 x 400 x 200

1x Ø 200 x 400 1x Ø 400 x 200 1x 400 x 400 x 200

16-piece set includes

4x 200 x 200 x 200 2x 400 x 200 x 200 2x 400 x 400 x 200

4x Ø 200 x 400 2x Ø 400 x 200 2x 400 x 400 x 200



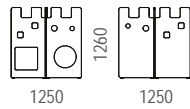

LK31 Exercise castle

The exercise castle can be utilised in play and exercise circuits. You can peek, crawl and throw a ball through the holes. The walls of the castle are attached to each other with hinges and the furniture can be folded flat for storage. A locking mechanism keeps the walls in place securely when the furniture is open, which makes the castle safe and sturdy to use. The castle is compatible with the stands, which are sold separately.

Materials:

The frame is birch plywood coated with high-pressure laminate. Primary colours. There is hinges and a locking mechanism, which locks the wall open. Screw-in anti-slip studs as standard.

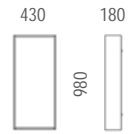

Size of a mirror

AS30 Funhouse mirror set

Materials:

Lacquered solid birch frames. Distorting mirrors, three different models. The mirrors are made of plastic and are hung with concealed fastenings



LK20 Stand



LK21 Slide



LK22 Stairs



Materials:

Lacquered plywood frame, the top is coated with Acoustic coating. Primary colours.



LK20



LK21



LK22



LK25 Trolley for stands

Materials:

Lacquered solid birch frame, the bottom of the trolley is made of birch plywood. Lockable wheels.



KS20 Motor skills arc

KS21 Mat for the arc

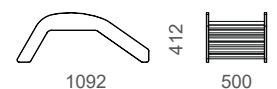

Materials:

Lacquered solid birch bars, birch plywood sides. Mat comes as an optional extra, upholstered with Enstex fabric. Primary colours of red, green, blue and yellow. There is an attachment mechanism at the end of the mat, which can be used to attach the mat to the bars.



The climbing area underneath the climbing and motor skills walls (about 2 m) has to be designed so that there is no risk of children hurting themselves if they fall. It is recommended that the floor of the climbing area is equipped with mats.



KS1 + KS2 + KS3 Climbing wall



KS5 Climbing wall, low

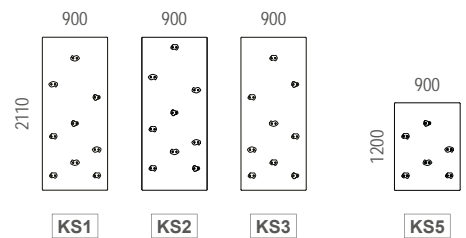

Materials:

The climbing wall is made of 18 mm birch plywood, and it is attached to the wall. The boulders are plastic, and are shaped so that it is easy for a child to use them as a support when climbing. The weight limit is 80 kg.



KS11 Rope climbing wall



KS10 Motor skills wall

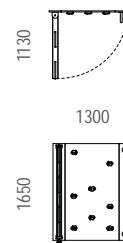

KS12 Safety board to prevent climbing

Materials:

Rope net., The frame is made of lacquered birch plywood. Must be attached to a sturdy, weight-bearing wall.

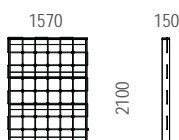

Materials:

18 mm lacquered birch plywood backboard, which is attached to the wall. The boulders are plastic, the pole is painted steel, colour RAL 7042 grey. Rope net. The net element can be opened and closed with hinges and it locks to it is place with safety locks. The backboard has to be attached to a sturdy and bearing wall. The weight limit is 50 kg. Safety board to prevent climbing comes as an optional extra.





VP1 Gymnastic mat,
flodable 1400 x 700 x 70 mm



VP2 Gymnastic mat,
1400 x 700 x 70 mm

Materials:

Interior is foam rubber E23. Detachable, durable and water-washable Enstex upholstery, which can be washed in at 60 °C. The basic colours for upholstery are blue, red and green.



VP10 Mat trolley,
VP2 for gymnastic mats



VP11 Mat trolley,
VP1 for gymnastic mats



V135 Trolley for sport equipment

Materials:

Lacquered solid birch sides, the bottom is lacquered birch plywood. Lockable wheels.

Materials:

Lacquered solid birch frame, lockable wheels. Aluminium handles.



VP10



VP11

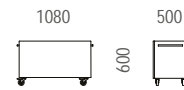

V135



P105 Gymnastic wall, low

P103 Slide

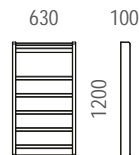

Materials:

The gymnastic walls and the sides of the slide are made of lacquered solid birch. The top of the slide is made of birch plywood coated with high-pressure laminate. Primary colours.





P111 **P112** **P111**



P121 **P122** **P121**



P221 **P222** **P221**

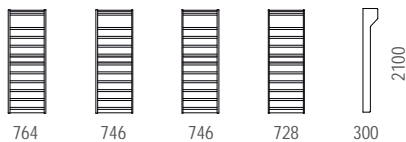

P220 **P221** **P221** **P222**
Single Left Right Middle

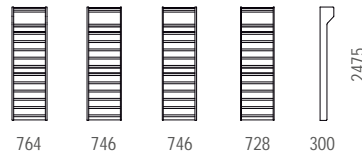

P230 **P231** **P231** **P232**
Single Left Right Middle

Materials:
Lacquered solid birch.



P110 **P111** **P111** **P112**
Single Left Right Middle

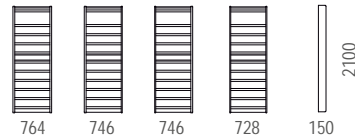

P120 **P121** **P121** **P122**
Single Left Right Middle

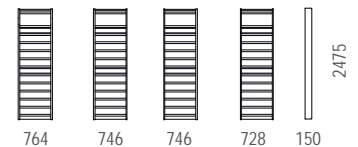

P130 **P131** **P131** **P132**
Single Left Right Middle



W112 Gymnastic bench

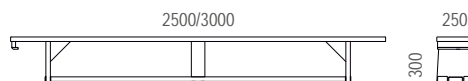

Materials:
Lacquered solid birch. Comes with screw-in anti-slip studs as standard. Gymnastic wall support at the end of the bench.





P300 Gymnastic wall and stage

Materials:

Lacquered solid birch bars, the back panel is made of veneer-coated furniture board. The stage is coated in sound-reducing Acoustic finish, available in primary colours. Gas-assisted springs for easy operation. Safe, uniform 130 mm strong edge. Locking profile is installed onto the wall at a height of 2300 mm and it will lock the stage in an upright position with two furniture locks per unit. Stairs available as an optional extra. The width of one module is 1510 mm.

Watch our product video at: www.woodi.fi/en/videos

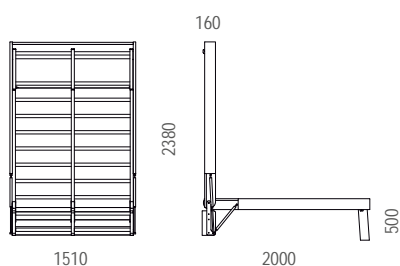

P310 Stairs

Materials:

Lacquered solid birch frame. The steps are coated with sound-reducing Acoustic finish, available in primary colours.

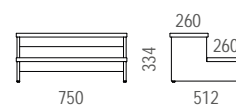



S707 Dressing bench



S706 Dressing bench

Materials:

Powder-painted steel piping frame, height-adjustable legs. The standard colour of the frame is grey RAL 7042. The seat is made of birch plywood coated with high-pressure laminate or Acoustic coating. Available in primary colours.

.Watch our product video at: www.woodi.fi/en/videos.



PP316
Dressing bench,
with shoe rack



PP315
Dressing bench



PP700
Bench



PP710
Bench, with shoe rack

Materials:

A dressing bench designed for small spaces. The surfaces are plywood coated with high-pressure laminate or Acoustic coating. Edges and corners are rounded. The shoe shelf and the frame are made of powder coated steel. The standard colour of the frame is grey RAL 7042. Height-adjustable legs, sturdy structure.

Materials:

Powder-painted steel piping frame, height-adjustable legs, sturdy structure. The standard colour of the frame is grey RAL 7042. The seat is made of furniture board coated with high-pressure laminate as standard. The seat is available in birch plywood coated with high-pressure laminate or Acoustic coating as a special order. Available in primary colours.

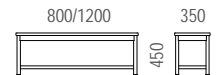
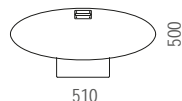
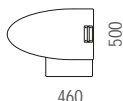
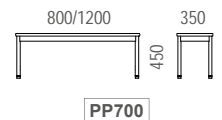
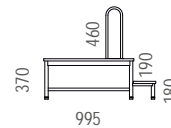
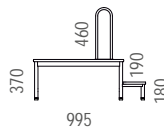
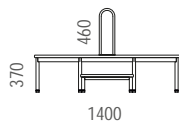
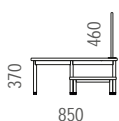

S707

S706

PP315

PP316

PP710





ETU302-70 Shoe rack



ETU214-90 Shoe rack, single-sided



ETU204-90 Shoe rack, double-sided

Materials:

The sides are made of lacquered solid birch or furniture board coated with white high-pressure laminate. ABS edge trim. Aluminium tube shelves, the droplet surfaces are made of HDF board coated with white high-pressure laminate. Height-adjustable steel tubing legs. Metallic droplet surfaces come as optional extras. The single-sided shoe rack can also be mounted onto the wall.

The depth of the single-sided shoe rack is 290 mm, and the double-sided rack is 540 mm.

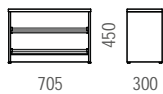

ETU301-70

ETU302-70

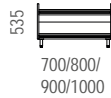

ETU212-90

ETU202-90

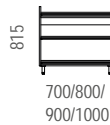

ETU213-90

ETU203-90

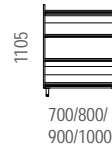

ETU214-90

ETU204-90

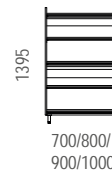

ETU215-90

ETU205-90



ETU216-90

ETU206-90



ETL105-90

Shoe rack, heatable



The heating unit can be placed vertically to dry other items such as mittens.



Each heating unit has its own switch breaker.

Materials:

The sides are made of lacquered solid birch or furniture board coated with white high-pressure laminate. ABS edge trim. Support boards are made of furniture board and the droplet surfaces are made of furniture board coated with white high-pressure laminate. The output of the heating units is 80 W. Can be connected with a single plug to an earthed socket, the length of the power lead is 1700 mm. Height-adjustable steel tubing legs.

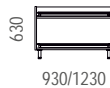

ETL102-90

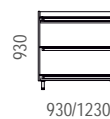

ETL103-90



ETL104-90



ETL105-90



EMMA

VEIKKO

INARIA

KEIU-LIIS

LUUKAS



N1000-2

Open compartments



N1000-3

With upper doors



N1000-4

With upper doors



N1020-4

N1000 wardrobe with lower and upper doors

Materials:

Lacquered solid birch frame, doors are made of birch plywood coated with high-pressure laminate or birch veneer. The doors and the seat are available in primary colours. Available double-sided with adjustable steel tube legs or lockable wheels as a supplementary order.

Equipment:

The wardrobe is available as a wall-mounted model or with height-adjustable steel tube legs.

The frame is made of lacquered solid birch.

In our basic laminate colours:

- doors
- seat

With open compartments or lower and/or upper doors.

Available with 2, 3 or 4 compartments.

Anchor hooks or rail for hangers.

618

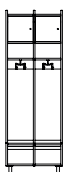

N1000-2

918

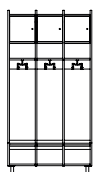

N1000-3

1218

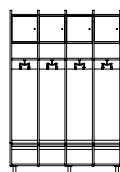

N1000-4

250



400

1800





N1300-2

With upper doors



N1300-3

With open compartments



N1300-4

With upper doors

Materials:

Lacquered solid birch frame, doors are made of birch plywood coated with high-pressure laminate or birch veneer. The doors and the seat are available in primary colours.

Equipment:

Wall-mounted model.

In our basic laminate colours:

- doors
- seat

The upper compartments with or without doors.

Available with 2, 3 or 4 compartments.

Anchor hooks or rail for hangers.

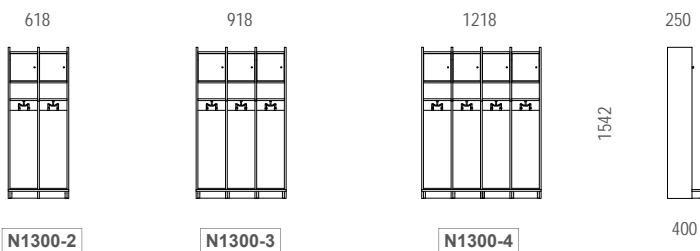

N1300-2

N1300-3

N1300-4





L905-3

With open compartments



L910-3

With doors



L920-3

With doors



L911-3



L911-3



L911-3



N800-3

With open compartments

Equipment:

The upper compartments are available with or without doors, with 2, 3 or 4 compartments. The bench comes with an aluminium tube grate for shoes.

Materials:

Lacquered solid birch frame, doors are made of birch plywood coated with high-pressure laminate or birch veneer. The doors and the seat are available in primary colours. Anchor hooks or rail for hangers.



N800-3

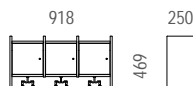

L905-3

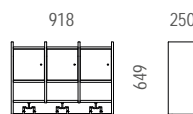

L910-3

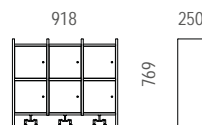

L920-3

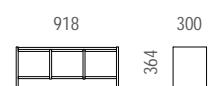

L911-3



W220-3 Wardrobe
PP701 Bench



W222-3 Double-sided wardrobe

Materials:

Lacquered solid birch frame, doors and the bench seat are made of furniture board coated with high-pressure laminate. Available in primary colours. Double-sided wardrobe comes with height-adjustable steel tube legs. The bench has a powder-painted steel piping frame and, height-adjustable legs. Available with 2, 3 or 4 compartments. There is an anchor hook, two regular hooks and a shelf inside one cabinet. Locks are available as optional extras.

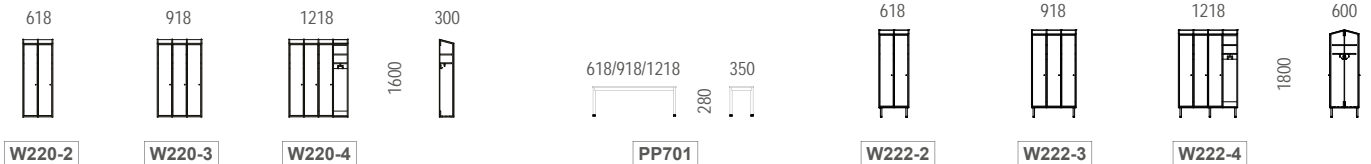

N1050-3 Wardrobe



N4000-3 Wardrobe

Materials:

Lacquered solid birch frame, anchor hooks. Aluminium tube grate for shoes. Height-adjustable steel tube legs. Available with 2 or 3 compartments.

Materials:

Lacquered solid birch frame, doors are made of furniture board coated with high-pressure laminate. Available in primary colours. White melamine back panel. Aluminium grate for shoes. Available with 2, 3 or 4 compartments.

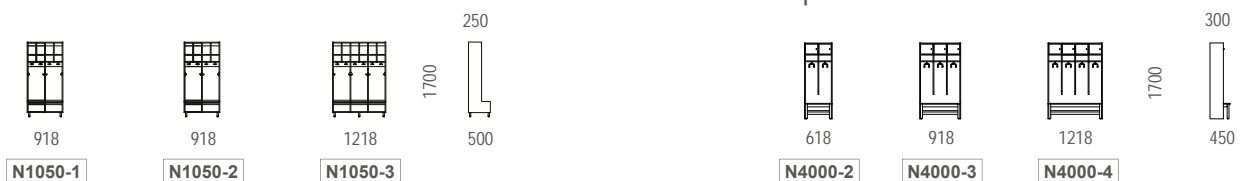



Plastic pocket

Made of polycarbonate, different sizes.

	WL504 A5	WL505 A6	WL506 C5	WL507 A6	WL508
Outer dimensions:	175 x 210 mm	130 x 150 mm	190 x 190 mm	170 x 130 mm	70 x 110 mm
Inner dimensions:	156 x 201 mm	112 x 141 mm	172 x 181 mm	152 x 121 mm	61 x 92 mm



Metal frame

Metallic frame. Suitable for a 35 x 73 mm sized nameplate. Can also be back ordered.

Outer dimensions:	45 x 84 mm
Inner dimensions:	25 x 65 mm



Name opening

A name label aperture has been made in the door.

Size: 35 x 60 mm



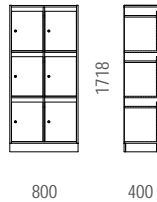

W250-32 Locker with letter boxes

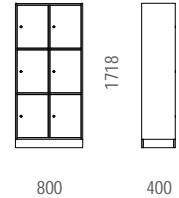

W245-32 Locker

Materials:

Lacquered solid birch frame, doors are furniture board coated with high-pressure laminate. Available in primary colours. The doors are fitted with knobs or locks. One locker has two compartments, each compartment can have 3 or 4 doors.



W230-23 Wardrobe

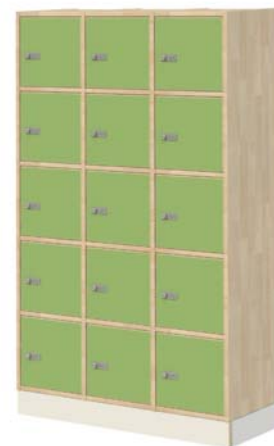

W240-53 Wardrobe

Materials:

Lacquered solid birch frame, doors are made of furniture board coated with high-pressure laminate. Available in primary colours. There are two shelves inside each cabinet. Height-adjustable steel tube legs. Available with 2, 3 or 4 compartments. Locks and hooks come as optional extras.

Materials:

Lacquered solid birch frame, doors and base are made of furniture board coated with high-pressure laminate. Available in primary colours. The doors are delivered with combination locks, standard locks or without locks. The picture with combination locks. Available with 2, 3 or 4 compartments. Each compartment can have 1-5 doors.

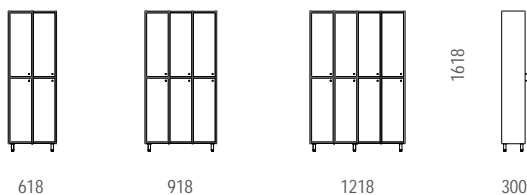

W230-22

W230-23

W230-24

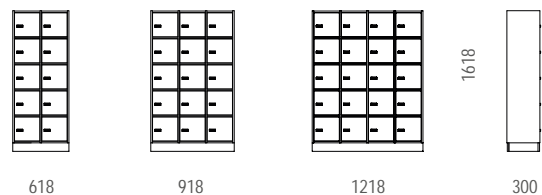

W230-22

W230-23

W230-24





Z400-4 Z wardrobe,
4 doors



PP701 Bench

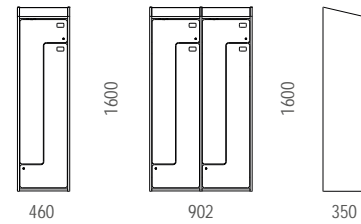

Z400-2

Z400-4

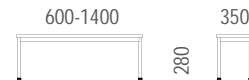

PP701

Materials:

Lacquered solid birch frame, doors are made of furniture board coated with high-pressure laminate. Available in primary colours. Aluminium tube grate for shoes. Stainless steel knobs, two regular hooks and an anchor hook inside each cabinet. The wardrobe is mounted onto the wall. Name label aperture and acrylic pocket (size A5) come as an optional extra.

The bench has a powder-painted steel piping frame and, height-adjustable legs. The standard colour of the frame is grey RAL 7042. The seat is made of lacquered solid birch or furniture board coated with laminate or Acoustic coating. Available in primary colours.



W218-4 Wardrobe



W218-4 + W194 Wardrobe and bench

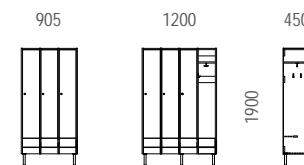

W218-3

W218-4

Materials:

Lacquered solid birch or furniture board frame, doors are made of furniture board coated with high-pressure laminate or birch veneer. Available in primary colours. Stainless steel knobs. Ventilated structure, aluminium grate for shoes. Rail for hangers, anchor hook and two regular hooks inside each cabinet. Height-adjustable steel tube legs. Locks come as optional extras. Available with 2, 3 or 4 compartments.



W194 Bench



Materials:

Lacquered solid birch frame, the seat is made of lacquered solid birch or furniture board coated with high-pressure laminate or Acoustic coating. Available in primary colours. The legs come with screw-in anti-slip studs as standard.





W133 Coat stand

W133-2 Coat stand

Materials:

Lacquered solid birch sides and shelves, base furniture board coated with high-pressure laminate. Available in primary colours. Hanger rail and six hooks.



W188-600 Wall rack



W188-1200 Wall rack

Materials:

Lacquered birch veneer. Frame and hooks are chrome-plated steel.



N10 Hook rack



N20 Hook rack



N30 Hook rack

Materials:

The board is made of lacquered solid birch. The hooks are chrome-plated steel.

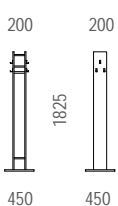

W133

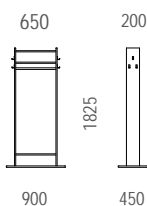

W133-2

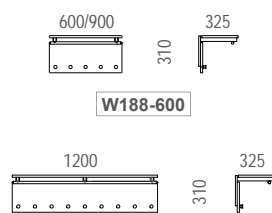

W188-1200

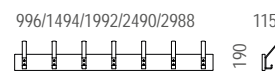

N20

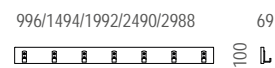

N10

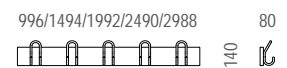

N30



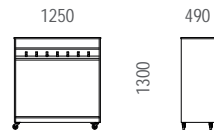

W198 Transportable rack

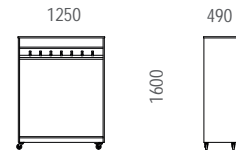

W199 Transportable rack

Materials:

Lacquered solid birch frame. Rail for hangers, 14 hooks. Aluminium tube grate for shoes. Lockable wheels.

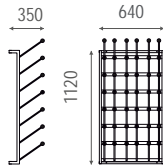

W189
for 21 pairs

W189

Boot rack, single-sided



W1890-32

Boot rack, double-sided

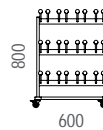

W1890-24
for 24 pairs

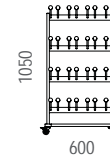

W1890-32
for 32 pairs

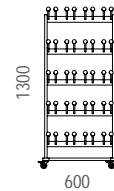

W1890-40
for 40 pairs

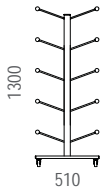

Materials:

Powder-painted steel frame; the basic colour is RAL 7042 grey. W1890 models with lockable wheels.

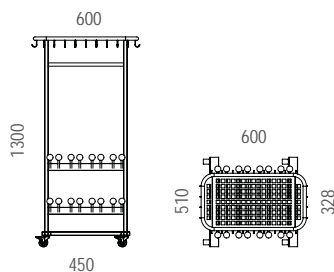

W190K Clothing rack

Materials:

Powder-painted steel, white. Lockable wheels.

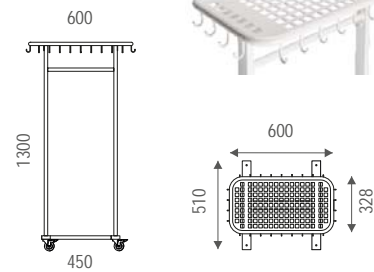

W190 Clothing rack

Materials:

Powder-painted steel, white. Lockable wheels.

Fold-out bed with fixed guard rails

- A fold-out bed designed for kindergartens.
- Beds come with fixed guard rails
- The ladder can be locked in an upright position, so that it functions as a guard rail at the end of the upper bed.
- Complies with the safety requirements set out in standard SFS-EN 1129-1



Fold-out bed designed for children in cooperation with kindergartens



VK550UT

Fold-out bed with fixed guard rails,
The size of the mattress 50 x 550 x 1400 mm



1950 mm

Fold-out bed designed especially for low spaces.

VK555

Low fold-out bed with fixed guard rails,
The size of the mattress 50 x 550 x 1200 mm

Materials:

The cabinet and the door of the fold-out bed are made of white furniture board as standard. Lacquered solid birch beds and ladder. The frame and the door are available with birch veneer or high-pressure laminate coating as a supplementary order. Primary colours. Bed linen and mattresses are available as optional extras. The size of the mattress is the same for both the upper and the lower bed. A cabinet for bed linen can be assembled next to the fold-out bed.

Watch our video about the making of the bed: www.woodi.fi/en/videos

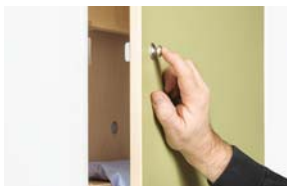

A lock on the door



Fixing of the door to the side of the upper bed



The upper bed has a protective board at the end of the bed



The bed is locked in the storage position

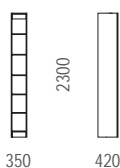

VK525U

Cabinet for bed linen

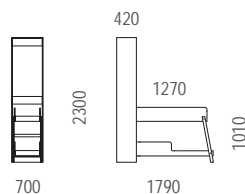

VK550UT

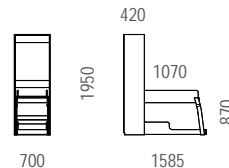

VK555

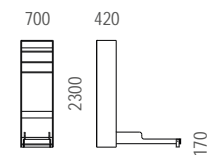

VK536

Fold-out bed for one person



Fold-out bed with hinged guard rails

- Fold-out bed with a guard ladder which can be locked in an upright- or horizontal position. Designed for kindergartens.
- The ladder can be locked in an upright position, so that it creates a guard rail at the end of the upper bed.
- The upper bed comes with guard rails as standard. Guard rails for the lower bed are available as optional extras.

VK500UT

Fold-out bed with hinged guard rails,
mattress size 50 x 550 x 1400 mm

Materials:

The cabinet and the door of the fold-out bed are made of white furniture board as standard. Lacquered solid birch beds and ladder. The frame and the door are available with birch veneer or high-pressure laminate coating as a supplementary order. Primary colours. Bed linen and mattresses are available as optional extras. The size of the mattress is the same for both the upper and the lower bed. A cabinet for bed linen can be assembled next to the fold-out bed.

Watch our video about the making of the bed: www.woodi.fi/en/videos



A lock on the door



Fixing of the door to the side of the upper bed



Fixing the guard rail to an upright position



The upper bed has a protector board at the end of the bed



The bed is locked into storage position.

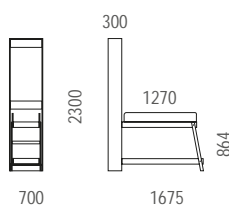

VK500UT

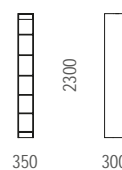

VK520U

Cabinet for bed linen

Technical information for fold-out beds

VK500UT	Fold-out bed with safety ladder, white furniture board, hinged guard rails on the upper bed
VK550UT	Fold-out bed with safety ladder, white furniture board, fixed guard rails on the upper and lower bed
VK555	Fold-out bed with safety ladder, white furniture board, fixed guard rails on the upper and lower bed
VK536	Fold-out bed for one person, white furniture board, fixed guard rails
VK520U	Cabinet for bed linen, white furniture board, five shelves included
VK525U	Cabinet for bed linen, white furniture board, five shelves included
VK510U	Safety rail, solid birch, hinges and locks
P5514-5	Bed mattress, flammability SL 1 / SL 2, the cover is cotton or hygienic fabric fitted with a zip

The cabinets and the doors can be coated with birch veneer or high-pressure laminate. The handles are fixed on the required side during production. The cabinet is benefits from **ventilation holes** when the doors are closed.

The bunk bed folds inside the cabinet with **two gas-assisted springs**. The bed has a lacquered solid birch frame. The base of the bed is made of perforated birch plywood. The bed is locked in the storage position with a locking mechanism. The door can be locked at the edge of the bed. VK500UT, VK550UT and VK555 are equipped with **fold-able ladders**, which can be folded to function as a guard rail for the end of the upper bed.

Measurements

VK500UT	W 700, D 300, H 2300. The height includes the base, H 50 mm.
VK550UT	W 700, D 420, H 2300. The height includes the base, H 50 mm.
VK555	W 700, D 420, H 1950. The height includes the base, H 50 mm.
VK536	W 700, D 420, H 2300. The height includes the base, H 50 mm.
VK520U	W 350, D 300, H 2300. The height includes the base, H 50 mm.
VK525U	W 700, D 300, H 2300. The height includes the base, H 50 mm.
VK510U	Guard rail, length 1200 mm, height 150 mm.
P5514-5	Mattress, width 550 mm, length 1400 mm, height 50 mm.
P5514-5-K	Hygienic mattress, width 550 mm, length 1400 mm, height 50 mm.



Non- standard heights available upon request.

The cabinets are fixed onto the wall with three fixing strips installed on the backboard of the cabinet. The strips are fixed horizontally and they have following dimensions: height 140 mm, thickness 18 mm. The middle points of the strips are at the following heights when measured from the floor: 140 mm, 1165 mm and 2210 mm. The tolerance is +/- 40 mm. The base of the cabinet has a 16 x 55 mm hole for the baseboard.

Measurements for opened fold-out bed:

	VK500UT	VK550UT	VK555
A The bed height of the lower bed, measured from the floor to the top of the side of the bed	168 mm	168 mm	168 mm
B The bed height of the upper bed, measured from the floor to the top of the side of the bed	864 mm	1010 mm	870 mm
C The height of the upper bed measured from the floor to the bottom of the bed	796 mm	796 mm	655 mm
D Required space for the fold-out bed when measured from the wall outwards	1675 mm	1790 mm	1585 mm

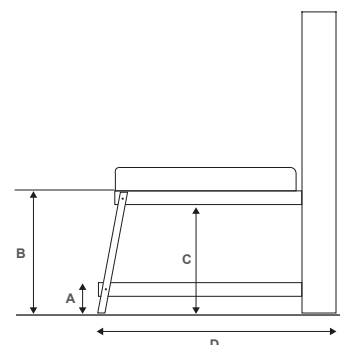



HK101-600

Cabinet, with a rail for hangers



HK102-600 Cabinet



HK102-800 Cabinet



PK601

Mattress cabinet



PK600

Mattress cabinet

Materials:

The frame of the cabinet is made of white furniture board as standard. Also available with birch veneer coating as a supplementary order. The door is made of white furniture board as standard, also available with high-pressure laminate or birch veneer coating as a supplementary order. Locks come as optional extras.

Cabinets HK102-600/800 have height-adjustable shelves as standard.

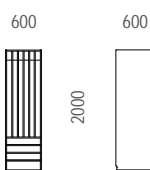

PK601

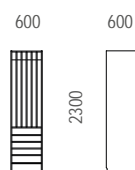

PK600

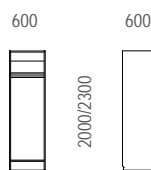

HK101-600

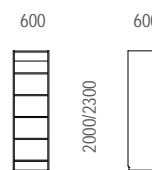

HK102-600

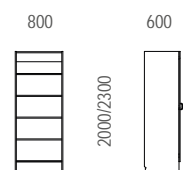

HK102-800





W175 Pillow, 350 x 400 mm

Fabric meets SL2 standard, 50 % cotton, 50 % polyester. Colour options: white, yellow or blue. Filled with carded polyester fibre fill. Washable in at 60 °C.



W177 Pillow case, 350 x 400 mm

Fabric 70 % cotton, 30 % polyester. Colour options: white, yellow or blue. Washable at 60 °C.



W176 Cover, 800 x 1200 mm

Fabric meets SL2 standard, 50 % cotton, 50 % polyester. Colour options: white, yellow or blue. Filled with carded polyester fibre fill. Washable in at 60 °C.



W178 Sheet, 1200 x 1700 mm

W179 Cover, 830 x 1300 mm

Fabric 70 % cotton, 30 % polyester. Colour options: white, yellow or blue. Washable at 60 °C

Mattresses for children's and adult's beds

Freon-free hypoallergenic foam rubber. The mattress cover is microfiber fabric, which is 100% polyester and fitted with a zip. Wash at 60°C. Fire-safety classification SL2, also available with fire-safety classification SL1.

The hygienic cover is made of waterproof, breathable and hypoallergenic fabric, of which one side is coated with polyurethane. Wash at 90 °C. Fabrics are compliant with the ÖKÖ-TEX 100 standard.



Foam rubber mattress with cotton polyester cover

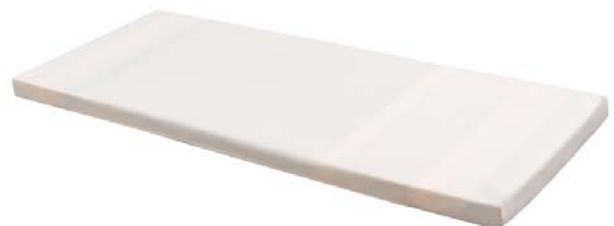

A protective cover is available as an optional extra for the foam rubber mattress. The protective cover is made of waterproof, breathable and hypoallergenic fabric. Easy to set up.



Breathable and hypoallergenic mattress with hygienic cover



The protective cover is fastened at both ends of the mattress





B502 + B505 + B506

Children's bunk bed



B502 + B502 + B552 + B505 + B506

Children's bunk bed, two-piece



B504

Children's bunk bed



B600

Cot



B508 + B508

Stackable bed



A573

Bed for adults



B602

Cot,
with a fold-down side

Materials:

Lacquered solid birch. Mattresses for the beds come as optional extras.

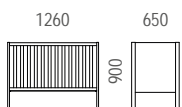

B600

B602

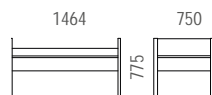

B502

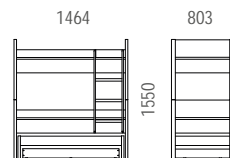

B502 + B502 + B552 + B505 + B506

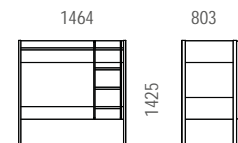

B504

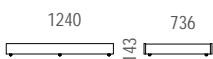

B506



B508



B505



A573





Foldable ladder

S210 Changing table

Materials:

The frame and the doors are made of furniture board coated with white high-pressure laminate. Lacquered solid birch ladder. The tabletop is made of waterproof Kerrock board. Stainless steel sink. Height-adjustable steel tubing legs.



The ladder folds under the table when it is in the upright position.

S220 Changing table, height-adjustable

Materials:

The tabletop and the front panels of the drawers are made of furniture board coated with white high-pressure laminate, the frame of the drawer and the ladder are lacquered solid birch. Height-adjustable base.



S203 Changing table

Materials:

The frame is made of lacquered solid birch or furniture board coated with white high-pressure laminate. The front panel of the drawer is made of furniture board coated with birch veneer or laminate. Available in primary colours. The drawer comes with steel rails. P203 padding with hygienic upholstery comes as an optional extra.



S204 Changing table, wall-mounted

Materials:

Lacquered solid birch frame, plywood back panel. The surfaces of the fold-out table are made of birch veneer or white furniture board. Gas-assisted springs. P204 padding comes as an optional extra.



SV23 Wall shelf for nappies

Materials:

White furniture board frame. Wall-mounted.



SP41 Wall shelf for pots

Materials:

The frame is made of furniture board coated with white high-pressure laminate. Solid shelves. Wall-mounted.

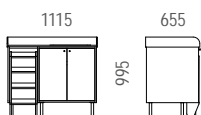

S210

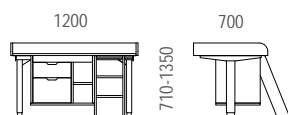

S220

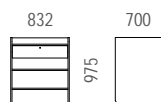

S203

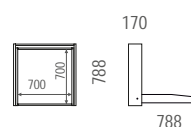

S204

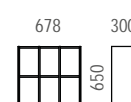

SV23

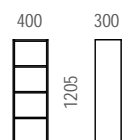

SP41



WOODI

For people



~ naturally durable

Woodi collections

Birch

Woodi furniture is made of solid birch and the material is classified as the highest quality (A/A). According to the classification, the surface has to be branchless and balanced in colour.

We use finger joint glue boards. This enables the best quality and balances any alterations in the surface.

Due to the solid birch we use, Woodi furniture is long-lasting and stays in good condition for many years.



Lacquer

OY Teknos AB, Modulen DA

Features:

- does not contain formaldehyde, ENV 717-1
- does not contain heavy metals
- EEC Toy Directive 88/378, EN 71.3
- saliva and sweat tests according to DIN 53160



High-pressure laminate

www.abetlaminati.com

Features:

- extremely good durability
- hygienic
- thickness 0.9 mm

High pressure laminate colors

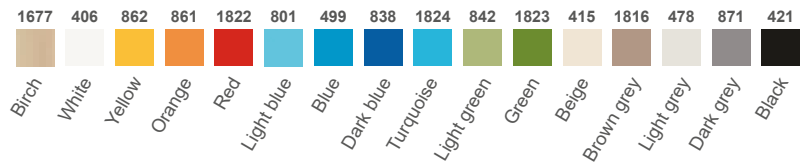

Acoustic

Gerflor Group, Taralay Uni Comfort
www.gerflor.fi

Features:

- noise reduction up to 17 Db

Acoustic colors

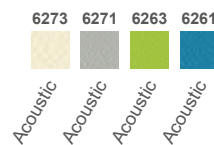

Maintenance for lacquered wood

Woodi products are treated with high-quality Nicolet furniture lacquer. Although the wooden surface is durable, it is a good idea to remember the following instructions when cleaning and maintaining the furniture.

- 1) Moisture damages lacquered surfaces. Always remove water and other liquids immediately from wooden surfaces.
- 2) A lacquered surface can be cleaned with a slightly damp cloth. Abrasive cleaning tools should be avoided.
- 3) Use very mild cleaning detergents only.

Maintaining laminate surfaces

The colourful surfaces of Woodi products are manufactured from durable, high-pressure laminate using modern materials and machinery. We guarantee that the products will meet your expectations whether you use them in dining rooms or play areas.

Hot objects on laminate surfaces

Boiling water or hot food will not damage laminate surfaces. However, a burning cigarette, hot iron or oven hot plates or pots can damage them.

Moisture

Water is not harmful to laminate surfaces, but it can damage the core material of tabletops. For this reason it is important to remove water from surfaces to prevent the water from absorbing into the material through seams.

Scratches

Normal cooking containers and dishes will not damage laminate surfaces. However, if you cut or scratch the laminate surface with a knife, the surface may be at risk of damage. Please use cutting boards when using knives and other sharp objects.

Cleaning

Clean laminate surfaces with water and mild detergent. Persistent stains can be removed by using non-abrasive fluid detergent and a soft brush. Our laminate surfaces will withstand most chemicals normally used in homes, including those that contain alcohol or cosmetic materials. Some chemicals or strong colour agents may damage the surface. Remove beetroot juice, juice concentrates, colour agents, chemicals, strong bleach or detergents immediately from laminate surfaces.

Spot	General detergent	Alcohol, window cleaner	Gasoline, acetone, turpentine	Special detergent
Fingerprint	x	x	x	
Grease, oils	x		x	
Soot, nicotine	x	(x)		
Marker pen, ink	x	x		
Coffee, tea	x			
Fruit	x			
Wax pens		x	x	
Ballpoint pen		x	x	
Permanent markers			x	x
Lacquer, glue, and wallpaper paste			x	x
Lipstick and shoe polish	x		x	





Experiences with furniture tendering

“The new kindergarten in Alajärvi was completed in July 2017. We started the planning process for freestanding furniture early on and got to know the different methods used in the competitive tendering process. At an early stage, we decided to use the “French competitive tendering” model. We specified the sum available to be used for the freestanding furniture and through the tendering process we got the opportunity to choose the most suitable furniture plan from different complete plans.

Woodi Oy from Kuopio was chosen as the winner for the freestanding furniture tendering process. The furniture plan presented by Woodi was distinctive and it fulfilled the invitation for tender criteria. It also made it clear that the company had an understanding of everyday life in early childhood education.

After the tendering process ended, everything ran smoothly. We went over the plans and the details together and made the necessary alterations and adjustments. We also agreed on the day of delivery, and when it arrived, the furniture was delivered and assembled in its correct place. The experience was really positive and the final results were exactly what we wished for.”

Hanna Luoma-aho

The early childhood education manager for the City of Alajärvi, Finland





We can help with planning

We are happy to assist our clients with furnishing projects, from individual spaces to whole buildings. We execute the plan according to the wishes and the budget of the client, using our many years of experience.

The right furniture makes a working environment ergonomic, functional, safe, and at the same time cosy. We help to choose colours and finishing materials for each project so that the furnishings are harmonious with the architecture of the building without overlooking usability and comfort. To support our design work we can produce 2D and 3D visualisations and room cards, which will help to demonstrate the final look.

Our product collection is constantly evolving and we can fit the furniture in each location cost-effectively, at all times considering high quality, durability and aesthetics. If you cannot find suitable furniture from our collection, please don't hesitate to contact our sales team about the different options available.

Basic space planning

Our basic space-planning package is available to order, and it will be included in the price of the furnishing project. The package will include space planning in terms of tables, chairs, storage units, sofas, armchairs and other freestanding furniture.

Additional space planning

Our chargeable additional space-planning package is customised according to customer's wishes and budget. This package may include a plan for curtains, carpets, lamps, acoustics and a complete colour scheme for the furniture.



Children's Day Award 2000

Kuopion Woodi Oy received an acknowledgement for their work to improve the environment for children from the Ministry of Education and Culture in 2000.



Ministry of Education and Culture
Opetus- ja kulttuuriministeriö Undervisnings- och kulturministeriet

Entrepreneurial Award 2011

The Federation of Finnish Enterprises in Eastern Finland awarded Kuopion Woodi Oy with the Entrepreneurial Prize in 2011.



Trustworthy Partner

Kuopion Woodi has received Suomen Asiakastieto's Rating Alfa AA+ classification, which means that Kuopion Woodi is a reliable partner. Only 10% of Finnish companies have received this classification.

Furniture testing

Kuopion Woodi furniture collections are tested according to standards SFS-EN 747-1, SFS-EN 747-2, SFS-EN 716-1, SFS-EN 16139, SFS-EN 15373, SFS-EN 1129-1, ISO 7173, ISO 7174-1, UNI EN 1022/98, ENV 1729-2/01, ENV 12520/2000 and EN 1728/2000.



Guarantee

All our furniture is guaranteed for five years, with the exception of bean bags, soft furnishings and floor cushions, which have a guarantee of one year. The guarantee covers material and production errors. Natural wear and damage that has resulted from unconventional use is not included in the guarantee. We also guarantee the future availability of our collections for at least ten years. Our oldest models date from 1994 and are still in production.

Company operations

We apply the ISO 9001 quality management system to our operations. The quality management system acts as an important tool in the continuous customer-oriented development of our products. Our customers see our quality management system as a reliable, trustworthy and eligible system.

Environment

We apply the ISO 14001 environmental standard to our operations. Our products are produced from environmentally friendly materials with environmental friendly technologies. Products that are at the end of their life cycle can be safely recycled or disposed of. During the production process, we strive to decrease the amount of waste materials and enhance the recycling and reuse of them.



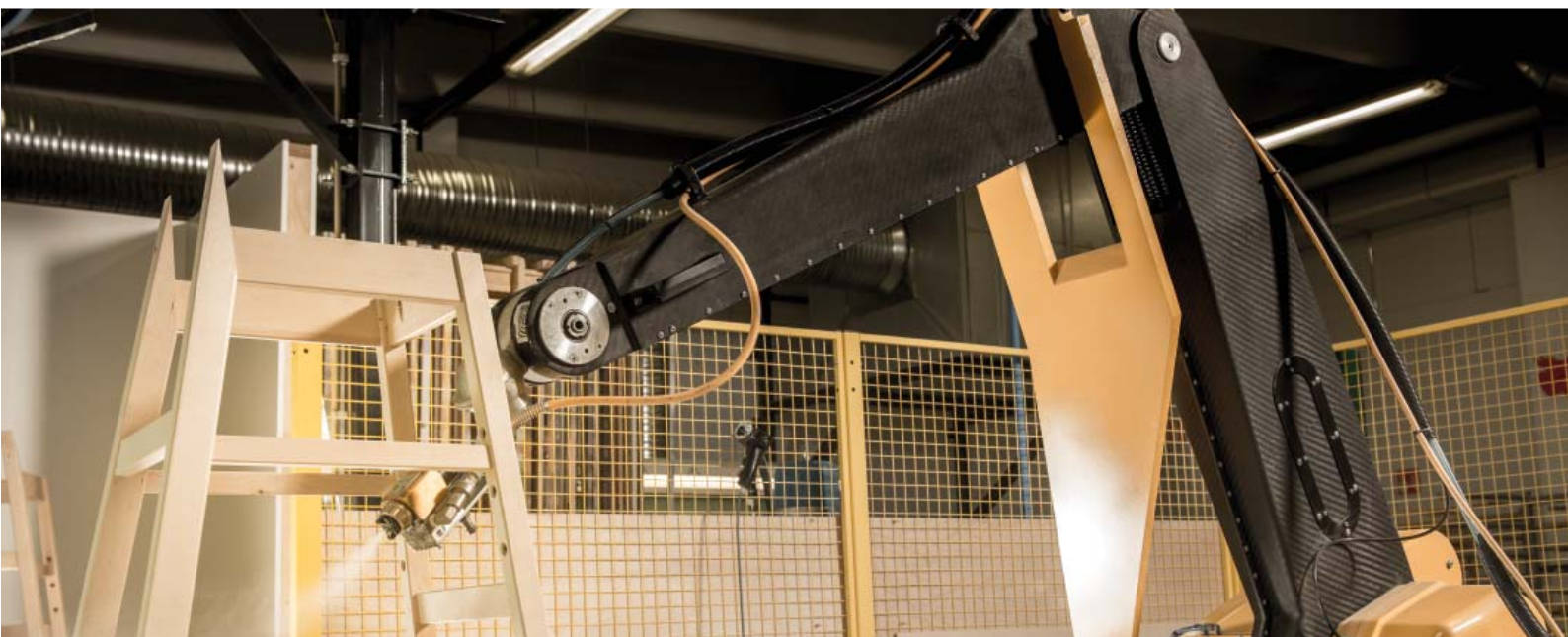

For people



~ naturally durable

Kuopion Woodi – a Finnish furniture manufacturer

Kuopion Woodi products are produced in a factory located in Kuopio, Finland. From the beginning, Kuopion Woodi has invested in the automatization of production and today Woodi is one of the most modern furniture factories in Finland. For our customers this means competitive prices and constant high quality.

Approximately 50 professionals from the wood industry work at Kuopion Woodi. We cooperate constantly with local schools, and most of our employees are young people at the start of their working lives. Many of our employees worked at Kuopion Woodi during their school internship. We want to maintain Finnish furniture manufacturing skills and to offer work for Finnish people in Finland.

Kuopion Woodi has been furnishing public spaces for over 20 years. Our collection offers a variety of products for public spaces, and especially for kindergartens, schools and retirement homes. The frame material of the products is high-quality solid birch and high-pressure laminate is used as an enhancement to bring colour, durability and character to the furniture. The furniture of Kuopion Woodi is designed to support the daily activities of our customers and to withstand hard use over a long period.

WOODI

Kuopion Woodi Oy, Ankkuritie 3, FI-70460 Kuopio, Tel +358 17 4652 061, www.woodi.fi, info@woodi.fi